



Compressor
Voltage Code : FZ

AE4430Z-FZ1A

High Temp. Commercial (HP)

220 - 240V 1~ 50 Hz

R452A / R404A / R448A / R449A

AE4430Z-FZ1A_BR

Conditions	Frequency	Nominal Cooling Capacity		Sound Power ISO3745 / ISO 3743-1
		Watts	BTU/h	
EN12900 / R452A	50 Hz	663	2261	54 dBA
EN12900 / R404A	50 Hz	661	2256	
EN12900 / R448A	50 Hz	664	2263	
EN12900 / R449A	50 Hz	664	2263	

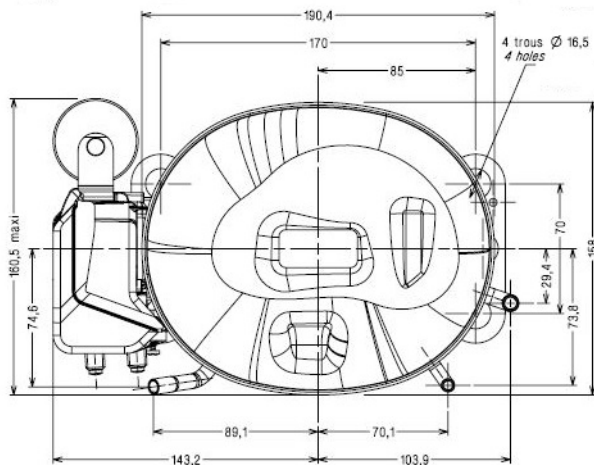
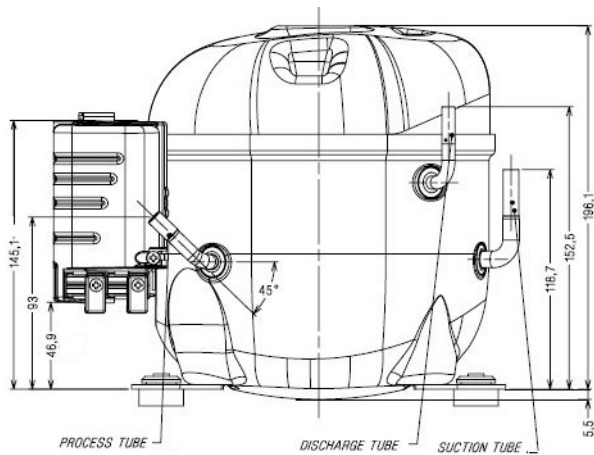

* EN12900 : T°Cond. 50.0°C / T°Evap. 5.0°C / T°Return gas temp.. 20.0°C
T°Subcooling. 0.0K

Certificates :



Displacement (cc)	5.16
Net Weight (Kg)	9.7
Oil Quantity (cc)	280.0
Oil Type	Polyolester
Expansion Device	Capillary_Tube/Expansion_Valve
Cooling	Fan
Main Winding (Ohm)	8.32
Start Winding (Ohm)	21.12
Current	
RLA (A)	2.14
LRA (A)	12.0
Electrical Equipment	CSIR
Overload	T14526
Time Check	6.5s - 16s / 8.00 A
Open Temp	120° C
Close Temp	52° C
Start Capacitor	64 µF / 330 V
Current Relay	RP40**
Pick Up	5.30A
Drop Out	4.45A
Refrigerating connection for OD	
Suction Tube	6.35 (1/4")
Discharge Tube	4.76 (3/16")
Process Tube	6.35 (1/4")

Note : Tecumseh reserves the right to change information contained in this document without notification.



Tecumseh

AE4430Z-FZ1A	Tension FZ : 220 - 240V 1~ 50 Hz
---------------------	-----------------------------------------

Les performances sont données dans les conditions EN12900 :	Gaz aspirés :	20.0 °C
Condition Dew	Sous refroidissement :	0.0 K
The performance data are in EN12900 conditions :	Return gas :	20.0 °C
Dew Condition	Subcooling :	0.0 K

50 Hz R452A											
											N°3048
4 T condensation	5 T évaporation	(°C)	-25	-20	-15	-10	-5	0	5	10	15
30	1 P frigorifique	(Watt)	236	309	396	501	625	772	943	1140	1367
	2 P absorbée	(W)	181	197	211	223	232	239	242	243	240
	3 I absorbée	(A)	1.56	1.60	1.64	1.68	1.70	1.72	1.74	1.75	1.75
40	1 P frigorifique	(Watt)		262	340	431	538	663	809	977	1170
	2 P absorbée	(W)		207	226	244	259	271	281	288	292
	3 I absorbée	(A)		1.60	1.67	1.72	1.78	1.82	1.86	1.89	1.92
50	1 P frigorifique	(Watt)			275	352	441	544	663	801	960
	2 P absorbée	(W)			238	262	283	303	320	334	345
	3 I absorbée	(A)			1.69	1.77	1.85	1.92	1.99	2.04	2.10
60	1 P frigorifique	(Watt)				265	335	415	507	614	738
	2 P absorbée	(W)				278	307	333	358	379	399
	3 I absorbée	(A)				1.82	1.92	2.02	2.11	2.20	2.28

50 Hz R404A											
											N°3050
4 T condensation	5 T évaporation	(°C)	-25	-20	-15	-10	-5	0	5	10	15
30	1 P frigorifique	(Watt)	252	326	414	519	644	789	959	1154	1377
	2 P absorbée	(W)	192	208	222	234	242	248	251	251	247
	3 I absorbée	(A)	1.65	1.69	1.73	1.76	1.78	1.79	1.80	1.80	1.80
40	1 P frigorifique	(Watt)	208	276	354	445	550	673	816	980	1167
	2 P absorbée	(W)	198	219	239	256	270	282	291	297	300
	3 I absorbée	(A)	1.63	1.70	1.76	1.81	1.86	1.90	1.93	1.95	1.97
50	1 P frigorifique	(Watt)		218	285	361	447	547	661	793	945
	2 P absorbée	(W)		227	252	276	297	315	331	344	354
	3 I absorbée	(A)		1.71	1.79	1.87	1.94	2.00	2.06	2.11	2.15
60	1 P frigorifique	(Watt)			210	270	336	412	498	597	712
	2 P absorbée	(W)			265	294	322	348	371	391	408
	3 I absorbée	(A)			1.83	1.93	2.02	2.11	2.19	2.26	2.33

1 = cooling capacity 2 = power input 3 = current 4 = condensing temperature 5 = evaporating temperature

Nota : Tecumseh se réserve le droit de modifier les informations contenues dans ce document sans préavis.

Note : Tecumseh reserves the right to change information contained in this document without notification.

© 2019 Tecumseh Products Company
All rights reserved



Tecumseh

AE4430Z-FZ1A	Tension FZ : 220 - 240V 1~ 50 Hz
---------------------	-----------------------------------------

Les performances sont données dans les conditions EN12900 :	Gaz aspirés :	20.0 °C
Condition Dew	Sous refroidissement :	0.0 K
The performance data are in EN12900 conditions :	Return gas :	20.0 °C
Dew Condition	Subcooling :	0.0 K

50 Hz R448A (*)											
											N°3051
4 T condensation	5 T évaporation	(°C)	-25	-20	-15	-10	-5	0	5	10	15
30	1 P frigorifique	(Watt)	208	279	364	467	591	737	908	1107	1337
	2 P absorbée	(W)	169	184	197	208	218	224	228	229	226
	3 I absorbée	(A)	1.45	1.49	1.53	1.57	1.60	1.62	1.64	1.65	1.64
40	1 P frigorifique	(Watt)		238	315	406	514	641	790	963	1163
	2 P absorbée	(W)		194	212	229	243	256	265	272	275
	3 I absorbée	(A)		1.50	1.56	1.62	1.67	1.72	1.76	1.79	1.81
50	1 P frigorifique	(Watt)			259	338	430	538	664	810	981
	2 P absorbée	(W)			225	248	269	288	304	318	329
	3 I absorbée	(A)			1.60	1.68	1.75	1.83	1.89	1.95	2.00
60	1 P frigorifique	(Watt)				265	341	429	532	652	791
	2 P absorbée	(W)				265	293	320	344	366	385
	3 I absorbée	(A)				1.73	1.84	1.94	2.03	2.12	2.20

50 Hz R449A (*)											
											N°3049
4 T condensation	5 T évaporation	(°C)	-25	-20	-15	-10	-5	0	5	10	15
30	1 P frigorifique	(Watt)	208	279	364	467	591	737	908	1107	1337
	2 P absorbée	(W)	169	184	197	208	218	224	228	229	226
	3 I absorbée	(A)	1.45	1.49	1.53	1.57	1.60	1.62	1.64	1.65	1.64
40	1 P frigorifique	(Watt)		238	315	406	514	641	790	963	1163
	2 P absorbée	(W)		194	212	229	243	256	265	272	275
	3 I absorbée	(A)		1.50	1.56	1.62	1.67	1.72	1.76	1.79	1.81
50	1 P frigorifique	(Watt)			259	338	430	538	664	810	981
	2 P absorbée	(W)			225	248	269	288	304	318	329
	3 I absorbée	(A)			1.60	1.68	1.75	1.83	1.89	1.95	2.00
60	1 P frigorifique	(Watt)				265	341	429	532	652	791
	2 P absorbée	(W)				265	293	320	344	366	385
	3 I absorbée	(A)				1.73	1.84	1.94	2.03	2.12	2.20

1 = cooling capacity 2 = power input 3 = current 4 = condensing temperature 5 = evaporating temperature

(*) Veuillez vous référer strictement aux Recommandations d'Utilisation et Bulletins Marketing Tecumseh du fait de la température de reflux élevée pour les applications LBP.
 (*) Due to very high discharge temperature especially on LBP conditions, please strictly refer to Tecumseh Guidelines & Marketing Bulletin when using this refrigerant.

Nota : Tecumseh se réserve le droit de modifier les informations contenues dans ce document sans préavis.

Note : Tecumseh reserves the right to change information contained in this document without notification.

© 2019 Tecumseh Products Company
All rights reserved