



Compressor
Voltage Code : FZ

THB4415YFZ

High Temp. Commercial (HP)

220 - 240V 1~ 50 Hz

R134a / R513A

THB4415YFZ

Conditions	Frequency	Nominal Cooling Capacity		Sound Power ISO3745 / ISO 3743-1
		Watts	BTU/h	
CECOMAF / R134a	50 Hz	319	1088	43 dBA
CECOMAF / R513A	50 Hz	325	1108	43 dBA

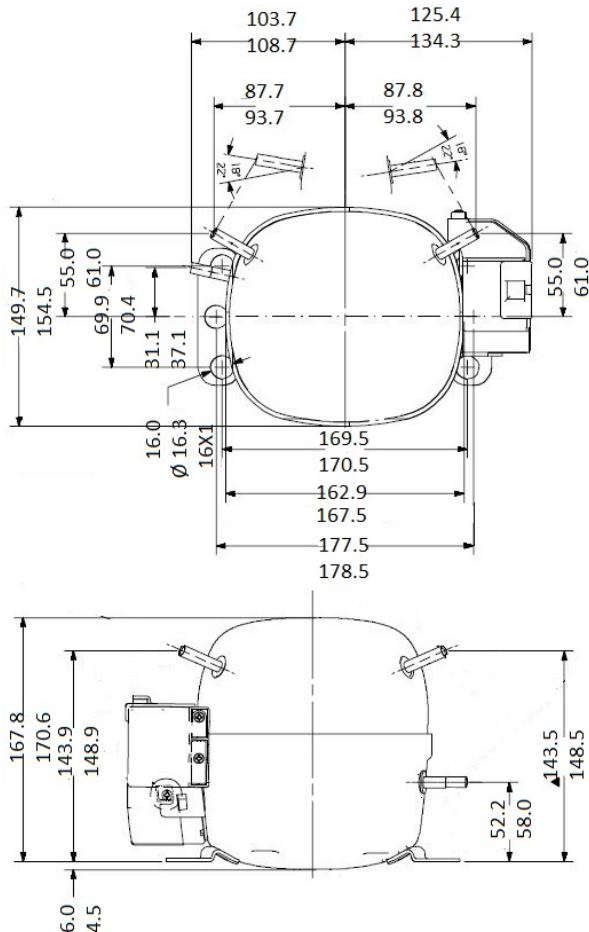

* CECOMAF : T°Cond. 55.0°C / T°Evap. 5.0°C / T°Return gas temp.. 32.0°C
T°Subcooling. 0.0K

Certificates :



Displacement (cc)	4,23
Net Weight (Kg)	7.3
Oil Quantity (cc)	250.0
Oil Type	Polyolester
Expansion Device	Capillary_Tube/Expansion_Valve
Cooling	Static
Main Winding (Ohm)	14.4
Start Winding (Ohm)	28.9
Current	
RLA (A)	1.2
MCC (A)	1.32
LRA (A)	7
Electrical Equipment	CSIR
Overload	T14529
Time Check	6.5s - 16s / 5 A
Open Temp	120° C
Close Temp	52° C
Start Capacitor	47-56 µF / 250 V
Current Relay	9660C-***-115
Pick Up	3,50A
Drop Out	2.95A
Optional	RP32**
Refrigerating connection for	
Suction Tube	6.35 (1/4")
Discharge Tube	6.35 (1/4")
Process Tube	4.76 (3/16")

Note : Tecumseh reserves the right to change information contained in this document without notification.



Tecumseh

THB4415YFZ	Tension FZ : 220 - 240V 1~ 50 Hz
-------------------	---

Les performances sont données dans les **conditions CECOMAF** :
 Condition Dew
 The performance data are in **CECOMAF conditions** :
 Dew Condition

Gaz aspirés : 32.0 °C
 Sous refroidissement : 0.0 K
 Return gas : 32.0 °C
 Subcooling : 0.0 K

© 2023 Tecumseh Products Company
All rights reserved

50 Hz R134a

N°211GE-FZ

4 T condensation	5 T évaporation	(°C)	-25	-20	-15	-10	-5	0	5	10	15
30	1 P frigorifique	(Watt)	102	137	182	236	300	375	461	558	667
	2 P absorbée	(W)	91.3	98.5	106	114	122	129	135	139	141
	3 I absorbée	(A)	1.01	1.02	1.04	1.05	1.07	1.09	1.11	1.12	1.14
40	1 P frigorifique	(Watt)		118	158	206	262	327	401	485	580
	2 P absorbée	(W)		103	112	122	132	141	149	156	161
	3 I absorbée	(A)		1.01	1.03	1.05	1.08	1.10	1.13	1.15	1.18
50	1 P frigorifique	(Watt)			133	176	225	281	346	418	499
	2 P absorbée	(W)			118	129	141	152	163	173	182
	3 I absorbée	(A)			1.04	1.07	1.10	1.13	1.16	1.19	1.23
60	1 P frigorifique	(Watt)				145	188	238	293	355	424
	2 P absorbée	(W)				136	150	165	178	192	204
	3 I absorbée	(A)				1.09	1.13	1.17	1.21	1.25	1.29

50 Hz R513A

N°3189

4 T condensation	5 T évaporation	(°C)	-25	-20	-15	-10	-5	0	5	10	15
30	1 P frigorifique	(Watt)	118	156	203	258	322	395	476	566	666
	2 P absorbée	(W)	101	108	115	122	130	137	145	152	159
	3 I absorbée	(A)	1.12	1.12	1.12	1.13	1.14	1.16	1.19	1.23	1.29
40	1 P frigorifique	(Watt)		132	174	223	279	343	415	495	583
	2 P absorbée	(W)		112	121	130	139	148	158	166	175
	3 I absorbée	(A)		1.10	1.11	1.12	1.14	1.16	1.19	1.23	1.28
50	1 P frigorifique	(Watt)			144	187	236	292	355	425	501
	2 P absorbée	(W)			126	137	148	160	171	182	193
	3 I absorbée	(A)			1.11	1.13	1.16	1.19	1.22	1.26	1.30
60	1 P frigorifique	(Watt)				151	193	242	295	355	421
	2 P absorbée	(W)				143	158	172	186	200	214
	3 I absorbée	(A)				1.15	1.19	1.22	1.26	1.30	1.35

1 = cooling capacity 2 = power input 3 = current 4 = condensing temperature 5 = evaporating temperature

Nota : Tecumseh se réserve le droit de modifier les informations contenues dans ce document sans préavis.

Note : Tecumseh reserves the right to change information contained in this document without notification.