



Compressor  
Voltage Code : TZ

**TAG4543Y**

High Temp. Commercial (HP)

400V 3~ 50Hz / 440V 3~ 60 Hz

R134a

AGB4543YTZ

Conditions	Frequency	Nominal Cooling Capacity		Sound Power ISO3745 / ISO 3743-1
		Watts	BTU/h	
EN12900 / R134a	50 Hz / 60 Hz	8883 / 10454	30290 / 35648	74 dBA

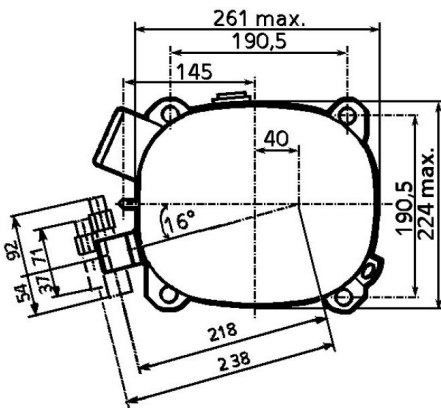
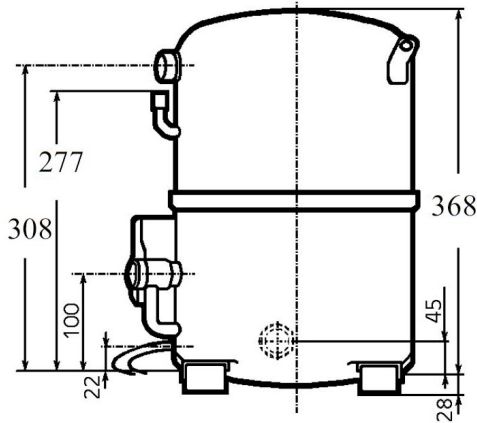

<b>Displacement (cc)</b>	124.4
<b>Net Weight (Kg)</b>	44.0
<b>Oil Quantity (cc)</b>	1760.0
<b>Oil Type</b>	Polyolester
<b>Expansion Device</b>	Capillary_Tube/Expansion_Valve
<b>Cooling</b>	Fan
<b>Main Winding (Ohm)</b>	4.6
<b>Current</b>	
RLA (A)	5.5   6.4
MCC (A)	10.7   10.5
LRA (A)	42   43
<b>Electrical Equipment</b>	TRI
<b>Overload</b>	Interne
<b>Refrigerating connection for OD</b>	
Suction Tube	22.2 (7/8")
Discharge Tube	15.9 (5/8")
Process Tube	6.35 (1/4")

\* EN12900 : T°Cond. 50.0°C / T°Evap. 5.0°C / T°Return gas temp.. 20.0°C  
T°Subcooling. 0.0K

Certificates :



Note : Tecumseh reserves the right to change information contained in this document without notification.



**Tecumseh**

<b>TAG4543Y</b>	<b>Tension TZ : 400V 3~ 50Hz / 440V 3~ 60 Hz</b>
-----------------	--

Les performances sont données dans les <b>conditions EN12900</b> :	Gaz aspirés :	20.0 °C
Condition Dew	Sous refroidissement :	0.0 K
The performance data are in <b>EN12900 conditions</b> :	Return gas :	20.0 °C
Dew Condition	Subcooling :	0.0 K

<b>50 Hz R134a</b>											
											<b>N°217JU-T</b>
4   T condensation	5   T évaporation	(°C)	<b>-25</b>	<b>-20</b>	<b>-15</b>	<b>-10</b>	<b>-5</b>	<b>0</b>	<b>5</b>	<b>10</b>	<b>15</b>
<b>30</b>	1   P frigorifique	(Watt)	2569	3137	4150	5590	7439	9678	12290	15259	18566
	2   P absorbée	(W)	963	1346	1693	2005	2281	2522	2728	2899	3034
	3   I absorbée	(A)	2.71	3.15	3.56	3.95	4.32	4.66	4.99	5.29	5.56
<b>40</b>	1   P frigorifique	(Watt)	2127	2581	3443	4693	6313	8283	10585	13200	16109
	2   P absorbée	(W)	950	1336	1705	2055	2387	2700	2996	3273	3532
	3   I absorbée	(A)	2.72	3.14	3.57	4.00	4.43	4.86	5.29	5.72	6.16
<b>50</b>	1   P frigorifique	(Watt)		2021	2733	3795	5187	6890	8883	11147	13662
	2   P absorbée	(W)		1327	1717	2106	2493	2879	3264	3647	4030
	3   I absorbée	(A)		3.14	3.58	4.04	4.53	5.05	5.59	6.16	6.75
<b>60</b>	1   P frigorifique	(Watt)			2018	2894	4061	5498	7186	9102	11227
	2   P absorbée	(W)			1729	2156	2599	3057	3532	4022	4528
	3   I absorbée	(A)			3.59	4.09	4.64	5.24	5.89	6.59	7.35

<b>60 Hz R134a</b>											
											<b>N°217JU-T</b>
4   T condensation	5   T évaporation	(°C)	<b>-25</b>	<b>-20</b>	<b>-15</b>	<b>-10</b>	<b>-5</b>	<b>0</b>	<b>5</b>	<b>10</b>	<b>15</b>
<b>30</b>	1   P frigorifique	(Watt)	2999	3718	4942	6649	8819	11431	14465	17902	21723
	2   P absorbée	(W)	1212	1662	2084	2478	2844	3183	3494	3776	4031
	3   I absorbée	(A)	2.50	2.97	3.46	3.95	4.45	4.96	5.48	6.01	6.54
<b>40</b>	1   P frigorifique	(Watt)	2476	3057	4100	5583	7484	9783	12457	15486	18849
	2   P absorbée	(W)	1208	1655	2099	2539	2976	3408	3837	4263	4685
	3   I absorbée	(A)	2.54	2.98	3.47	3.99	4.56	5.17	5.81	6.50	7.23
<b>50</b>	1   P frigorifique	(Watt)		2390	3254	4514	6150	8137	10454	13078	15987
	2   P absorbée	(W)		1650	2115	2601	3107	3634	4182	4750	5339
	3   I absorbée	(A)		2.99	3.48	4.04	4.67	5.37	6.15	7.00	7.91
<b>60</b>	1   P frigorifique	(Watt)			2403	3443	4814	6493	8456	10680	13139
	2   P absorbée	(W)			2131	2662	3239	3860	4526	5237	5993
	3   I absorbée	(A)			3.49	4.08	4.78	5.58	6.48	7.49	8.60

1 = cooling capacity 2 = power input 3 = current 4 = condensing temperature 5 = evaporating temperature

**Nota : Tecumseh se réserve le droit de modifier les informations contenues dans ce document sans préavis.**

**Note : Tecumseh reserves the right to change information contained in this document without notification.**

© 2019 Tecumseh Products Company  
All rights reserved