

UEMT6160Z

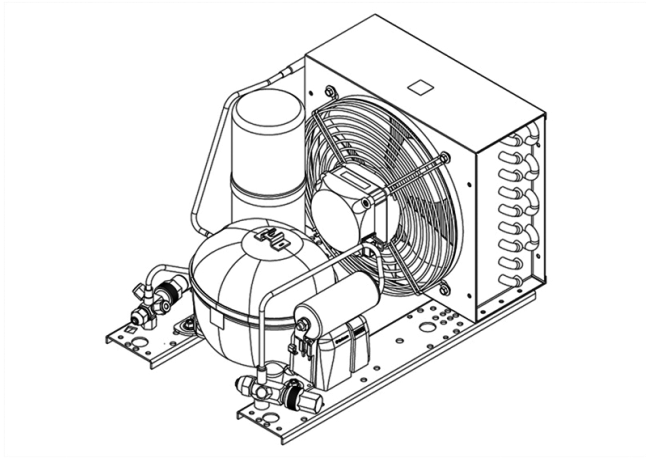

ENGINEERING CODE
594QA5212AA



REFRIGERANT
R-134a



POWER SUPPLY
220-240 V 50 Hz



APPLICATION
HBP



MOTOR TYPE
CSIR



STANDARD
EN13215_RG20



COOLING CAPACITY
388 W



EFFICIENCY
1.7 W/W

CE

ECODESIGN
COMPLIANT

DATA

GENERAL DATA

Model UEMT6160Z

ELECTRICAL DATA

Locked Rotor Amperage (LRA) 13.50 A

Rated Load Amperage (RLA) 1.87 A

Maximum Overcurrent Protection (MOP) 4.21 A

Minimum Current Ampacity (MCA) 2.3 A

ACCESSORIES

Discharge valve FLARE 1/4" 2110025

Suction valve FLARE 3/8" 2110024

CONDENSING COMPONENTS

Compressor EMT6160Z M/HBP

Condenser 3R9T 2451205

Refrigerant R-134a

Expansion Device C-V

Fan Blade Diameter 230 mm

Fankit 10W 230/31/5B 1996580

MECHANICAL DATA

Air Flow	420 m ³ /h
Height	254 mm
Receiver	1.1 L
Shaft Power	10 W
Weight	16 Kg
Width	300 mm
Length	435 mm

PERFORMANCE

TESTED CONDITIONS

Tested Refrigerant	R-134a
Tested Application	HBP
Tested Standard	EN13215_RG20

RATED POINTS

Ambient Temperature °C	Evaporating Temperature °C	Cooling Capacity W	Efficiency W/W	Consumo de Potencia W
32	-10	388	1.7	229

Test Condition: Subcooling 3 K, Return Gas 20 °C.

PERFORMANCE CURVE

Ambient Temperature 25°C

Evaporating Temperature °C	Cooling Capacity W	Efficiency W/W	Consumo de Potencia W
-15	348	1.71	203
-5	517	2.12	244
0	619	2.31	268
5	732	2.48	295
10	857	2.64	325

Test Condition: Subcooling 3 K, Return Gas 20 °C.

PERFORMANCE CURVE

Ambient Temperature 32°C

Evaporating Temperature °C	Cooling Capacity W	Efficiency W/W	Consumo de Potencia W
-15	315	1.51	209
-5	471	1.88	251
0	564	2.04	276
5	666	2.19	304
10	778	2.32	335

Test Condition: Subcooling 3 K, Return Gas 20 °C.

PERFORMANCE CURVE

Ambient Temperature 43°C

Evaporating Temperature °C	Cooling Capacity W	Efficiency W/W	Consumo de Potencia W
-15	283	1.29	219
-5	420	1.57	268
0	499	1.68	297
5	585	1.78	328

Test Condition: Subcooling 3 K, Return Gas 20 °C.

ENVELOPE



EXTERNAL DIMENSIONS

