

UNEK6212Z

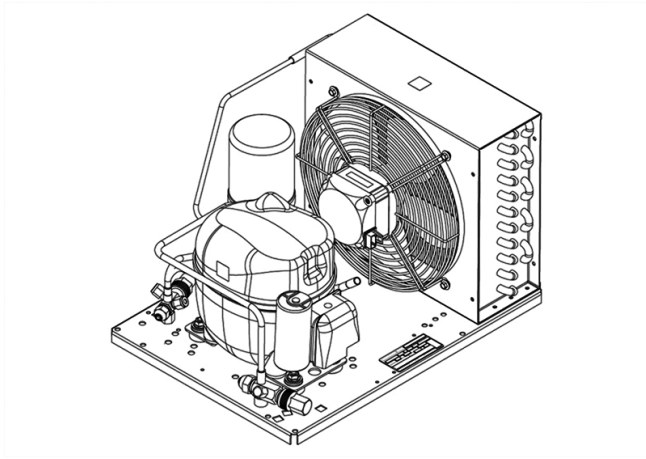

**ENGINEERING CODE**  
559BA5212AA



**REFRIGERANT**  
R-513A



**POWER SUPPLY**  
220-240 V 50 Hz



**APPLICATION**  
HBP



**MOTOR TYPE**  
CSIR



**STANDARD**  
EN13215\_RG20



**COOLING CAPACITY**  
700 W



**EFFICIENCY**  
1.47 W/W

CE

ECODESIGN  
COMPLIANT

DATA

GENERAL DATA

Model UNEK6212Z

ELECTRICAL DATA

Locked Rotor Amperage (LRA) 19.50 A

Rated Load Amperage (RLA) 3.95 A

Maximum Overcurrent Protection (MOP) 8.89 A

Minimum Current Ampacity (MCA) 4.9 A

ACCESSORIES

Discharge valve FLARE 1/4" 2110025

Suction valve FLARE 3/8" 2110024

CONDENSING COMPONENTS

Compressor NEK6212Z M/HBP

Condenser 3R11T 2451206

Refrigerant R-134a

Expansion Device C-V

Fan Blade Diameter 254 mm

Fankit 16W 254/28/5B 1996579

## MECHANICAL DATA

Air Flow	595 m <sup>3</sup> /h
Height	296 mm
Receiver	1.1 L
Shaft Power	16 W
Weight	22 Kg
Width	340 mm
Length	465 mm

## PERFORMANCE

### TESTED CONDITIONS

Tested Refrigerant	R-513A
Tested Application	HBP
Tested Standard	EN13215_RG20

### RATED POINTS

Ambient Temperature °C	Evaporating Temperature °C	Cooling Capacity W	Efficiency W/W	Consumo de Potencia W
32	-10	700	1.47	475

Test Condition: Subcooling 3 K, Return Gas 20 °C.

### PERFORMANCE CURVE

Ambient Temperature 25°C

Evaporating Temperature °C	Cooling Capacity W	Efficiency W/W	Consumo de Potencia W
-15	644	1.54	418
-5	926	1.81	511
0	1094	1.94	563
5	1280	2.07	618
10	1483	2.20	675

Test Condition: Subcooling 3 K, Return Gas 20 °C.

### PERFORMANCE CURVE

Ambient Temperature 32°C

Evaporating Temperature °C	Cooling Capacity W	Efficiency W/W	Consumo de Potencia W
-15	584	1.36	429
-5	835	1.59	524
0	989	1.71	576
5	1160	1.83	632
10	1347	1.95	691

Test Condition: Subcooling 3 K, Return Gas 20 °C.

## PERFORMANCE CURVE

Ambient Temperature 43°C

Evaporating Temperature °C	Cooling Capacity W	Efficiency W/W	Consumo de Potencia W
-15	481	1.08	445
-5	712	1.30	548
0	855	1.41	605
5	1016	1.53	665

Test Condition: Subcooling 3 K, Return Gas 20 °C.

## ENVELOPE



## EXTERNAL DIMENSIONS

