



Compressor
Voltage Code : FZ

RG5512W-FZ4A

Air Conditioning & Heating (CA)

220 - 240V 1~ 50 Hz

R407C

RG5512W-FZ4A

Conditions	Frequency	Nominal Cooling Capacity		Sound Power ISO3745 / ISO 3743-1
		Watts	BTU/h	
EN12900 / R407C	50 Hz	2220	7570	

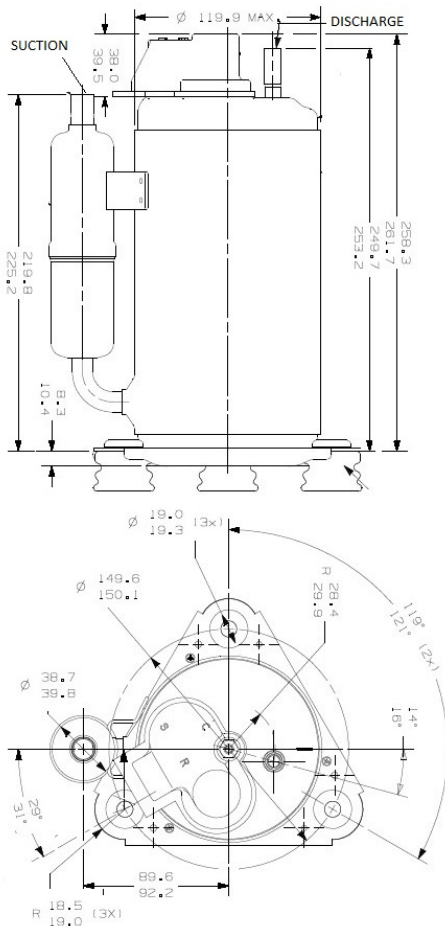

Displacement (cc)	16.1
Net Weight (Kg)	10.6
Oil Quantity (cc)	290.0
Oil Type	Polyolester
Expansion Device	Capillary_Tube/Expansion_Valve
Cooling	Fan
Main Winding (Ohm)	3.49
Start Winding (Ohm)	8.27
Current	
RLA (A)	4.1
LRA (A)	19.5
Electrical Equipment	CSR
Overload	MRA3736
Time Check	2s - 12s / 16 A
Open Temp	125° C
Close Temp	61° C
Start Capacitor	21-25 µF / 250 V
Run Capacitor	20 µF / 400 V
Potential Relay	RVA2C**
Pick Up	143/153V
Drop Out	40/90V
Refrigerating connection for OD	
Suction Tube	12.7 (1/2")
Discharge Tube	7.9 (5/16")

* EN12900 : T°Cond. 50.0°C / T°Evap. 5.0°C / T°Superheat. 10.0°C
T°Subcooling. 0.0K

Certificates :



Note : Tecumseh reserves the right to change information contained in this document without notification.



Tecumseh

RG5512W-FZ4A	Tension FZ : 220 - 240V 1~ 50 Hz
---------------------	---

Les performances sont données dans les conditions EN12900 :	Surchauffe :	10.0 K
Condition Dew	Sous refroidissement :	0.0 K
The performance data are in EN12900 conditions :	Superheat :	10.0 K
Dew Condition	Subcooling :	0.0 K

50 Hz R407C

N°RG5512W-FZ4A

4 T condensation	5 T évaporation	(°C)	-25	-20	-15	-10	-5	0	5	10	15
40	1 P frigorifique	(Watt)				1441	1776	2183	2685	3304	4063
	2 P absorbée	(W)				646	669	684	689	683	663
	3 I absorbée	(A)				3.35	3.44	3.50	3.52	3.49	3.41
50	1 P frigorifique	(Watt)					1518	1840	2220	2681	3246
	2 P absorbée	(W)					770	801	824	837	837
	3 I absorbée	(A)					3.85	3.98	4.08	4.14	4.14
60	1 P frigorifique	(Watt)						1518	1832	2190	2616
	2 P absorbée	(W)						927	968	1001	1023
	3 I absorbée	(A)						4.51	4.69	4.83	4.93

© 2020 Tecumseh Products Company
All rights reserved

1 = cooling capacity 2 = power input 3 = current 4 = condensing temperature 5 = evaporating temperature

Nota : Tecumseh se réserve le droit de modifier les informations contenues dans ce document sans préavis.

Note : Tecumseh reserves the right to change information contained in this document without notification.