



Compressor
Voltage Code : FZ

AE5470C-FZ3C

Air Conditioning & Heating (CA)

220 - 240V 1~ 50 Hz

R407C

AE5470C-FZ3C_BR

Conditions	Frequency	Nominal Cooling Capacity		Sound Power ISO3745 / ISO 3743-1
		Watts	BTU/h	
EN12900 / R407C	50 Hz	1572	5360	

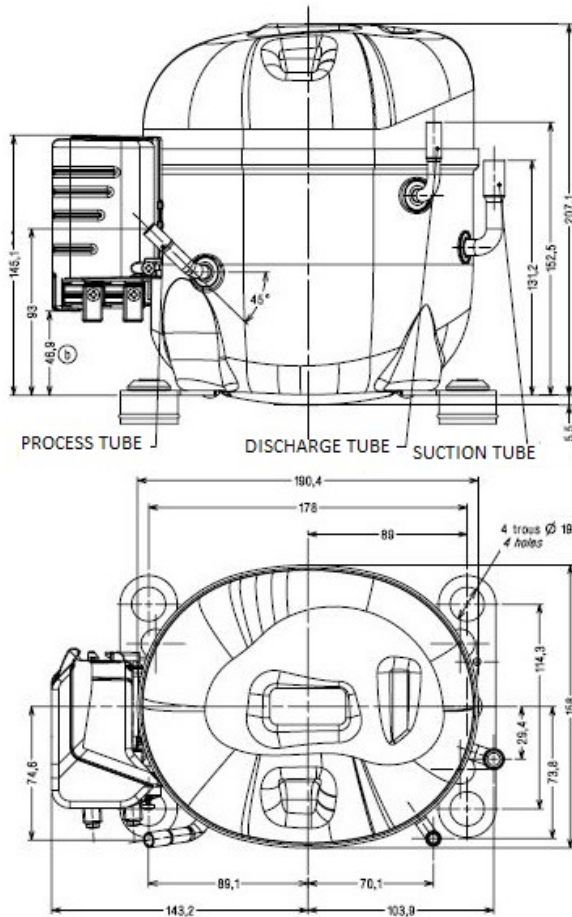

Displacement (cc)	12.0
Net Weight (Kg)	11.3
Oil Quantity (cc)	380.0
Oil Type	Polyolester
Expansion Device	Capillary_Tube
Main Winding (Ohm)	3.3
Start Winding (Ohm)	14.5
Current	
RLA (A)	3.4
LRA (A)	20
Electrical Equipment	CSR
Overload	T89031
Time Check	6.5s - 16s / 13 A
Open Temp	135°C
Close Temp	52°C
Start Capacitor	88 µF / 330 V
Run Capacitor	12 µF / 400 V
Potential Relay	RVA3AG**
Pick Up	180/195V
Drop Out	40/105V
Refrigerating connection for OD	
Suction Tube	9.5 (3/8")
Discharge Tube	6.35 (1/4")
Process Tube	9.5 (3/8")

* EN12900 : T°Cond. 50.0°C / T°Evap. 5.0°C / T°Superheat. 10.0°C
T°Subcooling. 0.0K

Certificates :



Note : Tecumseh reserves the right to change information contained in this document without notification.



Tecumseh

AE5470C-FZ3C	Tension FZ : 220 - 240V 1~ 50 Hz
---------------------	---

Les performances sont données dans les conditions EN12900 :	Surchauffe :	10.0 K
Condition Dew	Sous refroidissement :	0.0 K
The performance data are in EN12900 conditions :	Superheat :	10.0 K
Dew Condition	Subcooling :	0.0 K

50 Hz R407C

N°3015

4 T condensation	5 T évaporation	(°C)	-25	-20	-15	-10	-5	0	5	10	15
40	1 P frigorifique	(Watt)				936	1187	1482	1826	2225	2684
	2 P absorbée	(W)				486	523	556	588	617	643
	3 I absorbée	(A)				2.47	2.63	2.77	2.91	3.04	3.17
50	1 P frigorifique	(Watt)					1013	1271	1572	1922	2326
	2 P absorbée	(W)					570	613	654	692	727
	3 I absorbée	(A)					2.84	3.02	3.20	3.37	3.54
60	1 P frigorifique	(Watt)						1053	1311	1611	1959
	2 P absorbée	(W)						668	721	771	818
	3 I absorbée	(A)						3.29	3.51	3.72	3.93

© 2019 Tecumseh Products Company
All rights reserved

1 = cooling capacity 2 = power input 3 = current 4 = condensing temperature 5 = evaporating temperature

Nota : Tecumseh se réserve le droit de modifier les informations contenues dans ce document sans préavis.

Note : Tecumseh reserves the right to change information contained in this document without notification.