

PANASONIC SCROLL COMPRESSORS

Code : 809 966 88

Model : C-SBN453H8G

Aproved for R407C, R448A, R449A, R134a, R513A, R404A



Panasonic Appliances Compressor (Dalian) Co.,Ltd.

Section 1. General Specifications

Model <u>C-SBN453H8G</u>	Electrical <u>380-415 Volts 3 Phase 50Hz</u>
Refrigerant <u>R407C</u>	<u>440-460 Volts 3 Phase 60Hz</u>

Nominal Performance at ARI

	<u>50Hz-380V</u>	<u>60Hz-440V</u>
Power Source		
Capacity (W)	<u>17600</u>	<u>21300</u>
Power (W)	<u>5800</u>	<u>7000</u>
Current (A)	<u>9.93</u>	<u>10.2</u>
COP (W/W)	<u>3.03</u>	<u>3.04</u>
Mass Flow (kg/h)	<u>424</u>	<u>513</u>

Rating Conditions (MID Point)

Condensing Temperature(°C)	<u>54.4</u>
Evaporating Temperature(°C)	<u>7.2</u>
Return Gas temperature(°C)	<u>18.3</u>
Liquid Temperature(°C)	<u>43.8</u>
Ambient Temperature(°C)	<u>35</u>

Motor

	<u>50Hz</u>	<u>60Hz</u>
Voltage Range(V)	<u>342-456</u>	<u>396-506</u>
RLA (A)	<u>10.4</u>	
MCC (A)	<u>14.5</u>	
LRA (A)	<u>66</u>	<u>72</u>
RPM (min ⁻¹)	<u>2900</u>	<u>3450</u>

Compressor

Maximum Discharge Temp(°C)	<u>130</u>
Displacement (cm ³ /rev)	<u>100</u>
Weight (with oil kg)	<u>39.5</u>
VDE File Number	<u>40010537</u>

Oil

Oil Type	<u>FV68S</u>
Initial Charge (ml)	<u>1700</u>
Re-charge (ml)	<u>1600</u>

Electrical Components

Motor Protector Type	<u>Internal</u>
Run Capacitor Rating (MFD/Volts)	<u>n/a</u>

Winding Resistance at 25°C

	<u>2.478</u>
U-V	<u>2.478</u>
U-W	<u>2.478</u>
V-W	<u>2.346</u>

Sound level 50Hz/380V 60Hz/440V

(db)	<u>64Max</u>	<u>68Max</u>
------	--------------	--------------

Nominal performance values +/-5% with 1 hr run-in.

Ratings with air over compressor.

Sound level is an average sound pressure level in four directions. MIC location is the distance of 1m from the compressor Specifications subject to change without notice.

Minimum Starting Voltage

Power Source (3PH)	Hz	50	60
Minimum Starting Voltage	V	304	352

Conditions

Compressor Temp.	°C (°F)	10~60(50~140)
Ambient Temp.	°C (°F)	10~40(50~105)
High Pressure	MPa(G)/psig	2(290)
Low Pressure	MPa(G)/psig	0.5(72)

Inernal Motor Protector (in compressor)

Parts Name	Specification	
Inernal Motor Protector	TripTemp.	145±5°C
	Reset Temp.	61±9°C
	Trip Current	57A / 2~10s

Others

Content	Unit	Specification	
Design Pressure	L.P. S.	MPa(G)/psig	1.6(232)
	H. P. S.	MPa(G)/psig	3.3(479)
Insulation Resistance	MΩ	100 (without refrigerant)	
Dielectric Strength	v	2400 (1 second)	
Residual Moisture	mg	300	

Note:
1. The insulation resistance be measured with a DC500V megohm test

Accessories List

Parts Name	Qty	Parts code	Revision No.	Note
Terminal Box Cover	1	A-0101-DSB	0	Installed on Compressor
Terminal Box Clip	1	A-0201-DSB	0	Installed on Compressor
Insulating Grommet	1	A-0301-DSB	0	Installed on Compressor
Mounting Grommet	4	M-0101-DSB	0	Included with Compressor
Mounting Sleeve	4	M-0201-DSB	0	Included with Compressor
Screw Special	1	B-0101-DSB	0	Installed on Compressor

Section 2. Compressor Protection

2.1 Protection Required but not Included with compressor

Protection Device	Items	Specifications
Reversal Defensible Relay	Features	To protect the compressor from reverse rotation
	Rated Voltage	AC380V
Crankcase Heater	Rated Power	35 Watts
Discharge Thermostat	Mounting Position	Located within 100mm(4 in)from the compressor shell
	Trip Temperature	130±5°C(266 ±10 °F)
	Reset Temperature	95±11°C (205 ± 20 °F)
High Pressure Switch	Setting	Cut-out seting no higher than 3.2MPa(G)
Low Pressure Switch	Setting	Cut-out seting no lower than 0.05MPa(G)

2.2 Position of the Protection and Refrigerant Charging

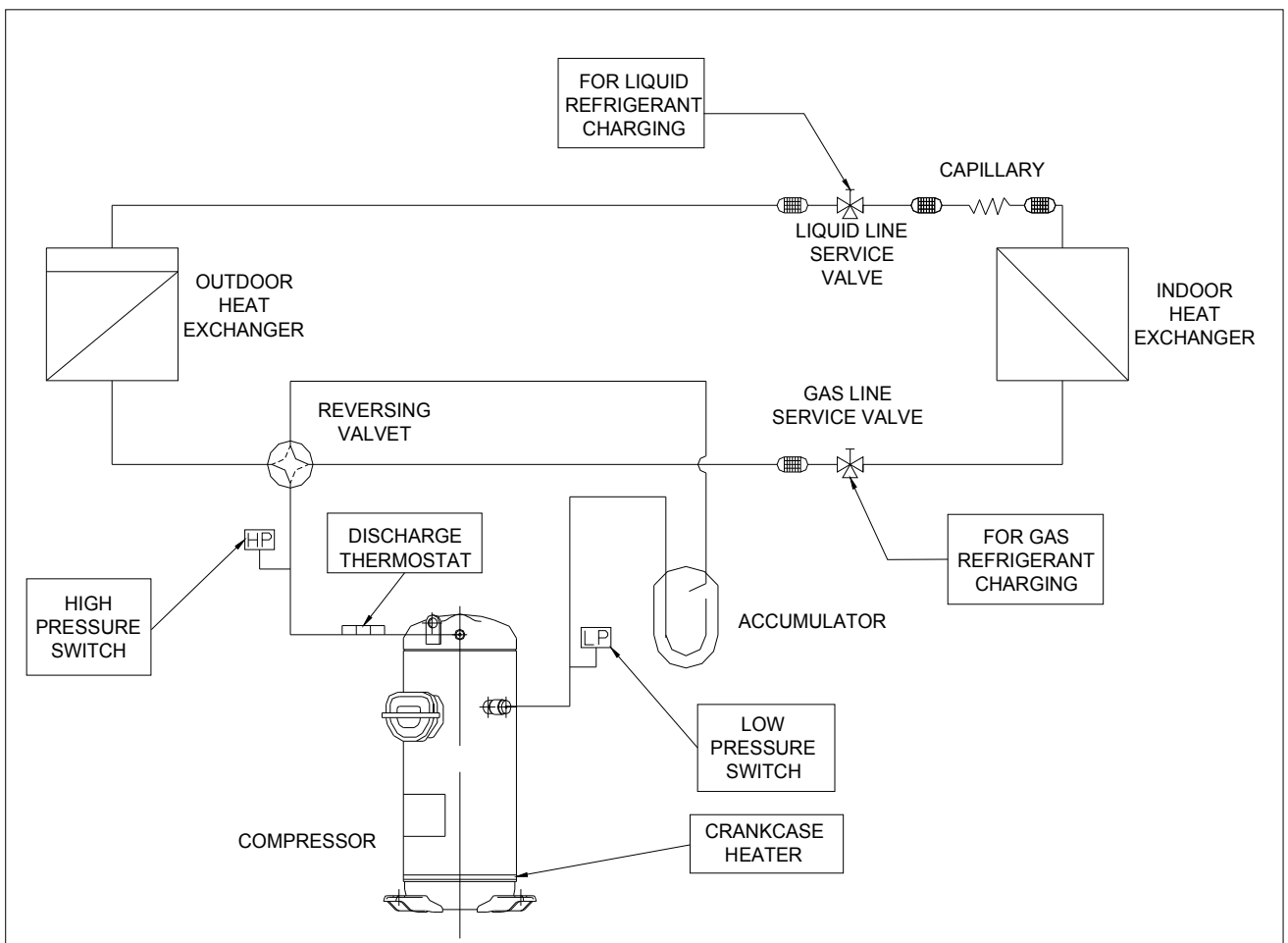

Section 3. Performance data

PERFORMANCE DATA

Compressor Model(Code)	C-SBN453H8G (809 966 88)
Power Source	3PH 50Hz 380-415V
Suction Gas Superheat(K)	9
Sub Cooling(K)	8.3
Compressor Cooling	Natural Cooling
Refrigerant	R407C

CAPACITY(W)

Condensing Temperature(°C)	Evaporating Temperature(°C)							
	-15	-10	-6.7	0	4.4	7.2	10	12
35.0	10,120	12,260	13,920	18,000	21,300	23,720	26,410	28,510
40.5	9,170	11,140	12,680	16,470	19,560	21,820	24,340	26,320
45.0	8,440	10,290	11,730	15,310	18,220	20,360	22,750	24,630
50.0	7,700	9,420	10,760	14,100	16,830	18,850	21,100	22,870
54.4		8,710	9,970	13,110	15,700	17,600	19,730	21,420
60.0			9,050	11,960	14,360	16,140	18,130	19,710
65.0				11,030	13,280	14,950	16,830	18,320

POWER(W)

Condensing Temperature(°C)	Evaporating Temperature(°C)							
	-15	-10	-6.7	0	4.4	7.2	10	12
35.0	3,580	3,610	3,620	3,650	3,670	3,680	3,690	3,690
40.5	4,070	4,090	4,110	4,140	4,150	4,160	4,170	4,170
45.0	4,530	4,560	4,580	4,610	4,620	4,630	4,630	4,640
50.0	5,130	5,160	5,180	5,200	5,210	5,220	5,220	5,220
54.4		5,750	5,770	5,790	5,800	5,800	5,800	5,800
60.0			6,600	6,630	6,630	6,630	6,620	6,610
65.0				7,450	7,450	7,440	7,430	7,420

CURRENT(A)

Condensing Temperature(°C)	Evaporating Temperature(°C)							
	-15	-10	-6.7	0	4.4	7.2	10	12
35.0	6.5	6.5	6.6	6.6	6.7	6.7	6.7	6.7
40.5	7.3	7.3	7.4	7.4	7.4	7.5	7.5	7.5
45.0	8.0	8.1	8.1	8.1	8.2	8.2	8.2	8.2
50.0	9.0	9.0	9.0	9.0	9.1	9.1	9.1	9.1
54.4		9.9	9.9	9.9	9.9	9.9	9.9	9.9
60.0			11.2	11.1	11.1	11.1	11.1	11.1
65.0				12.4	12.3	12.3	12.3	12.3

NOTE:

- * The performance values subject to change without notice.
- * The performance values are based on MID point method.

Compressor Model(Code)
Power Source

C-SBN453H8G (809 966 88)
3PH 50Hz 380-415V

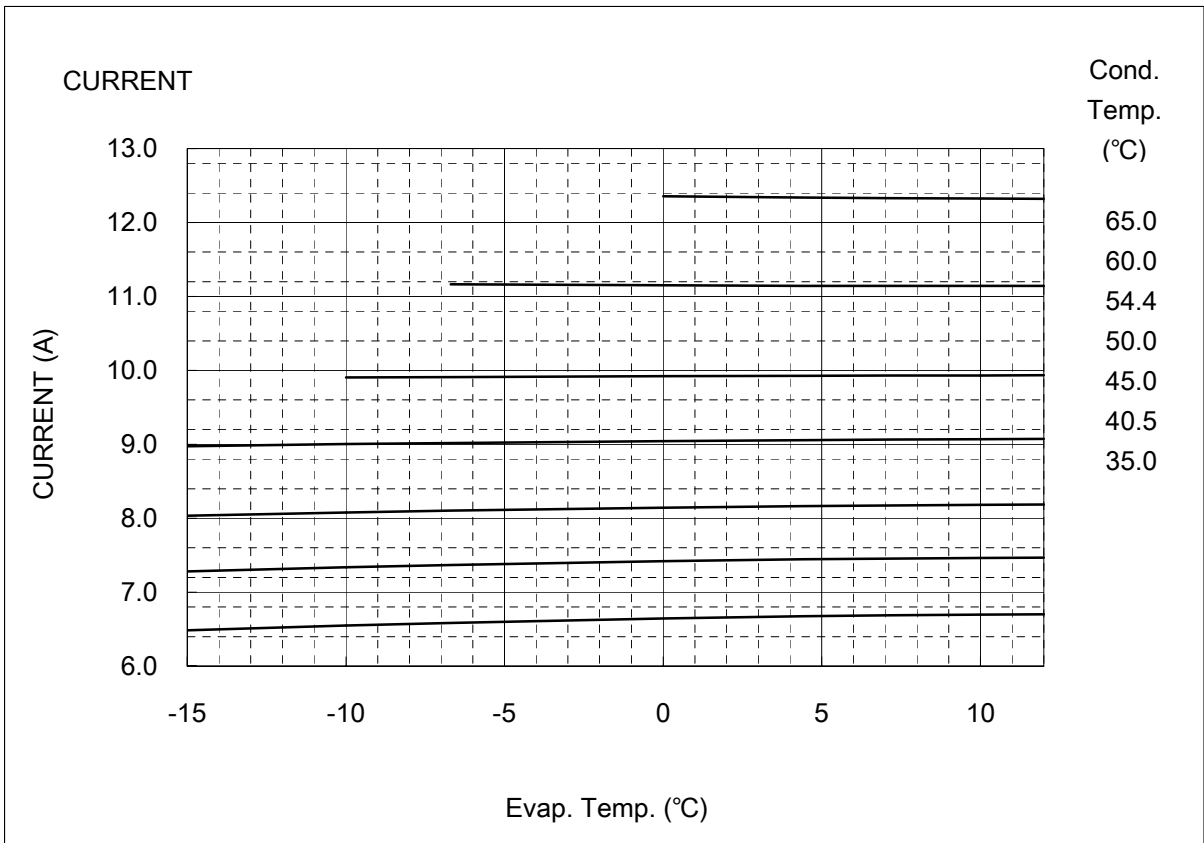
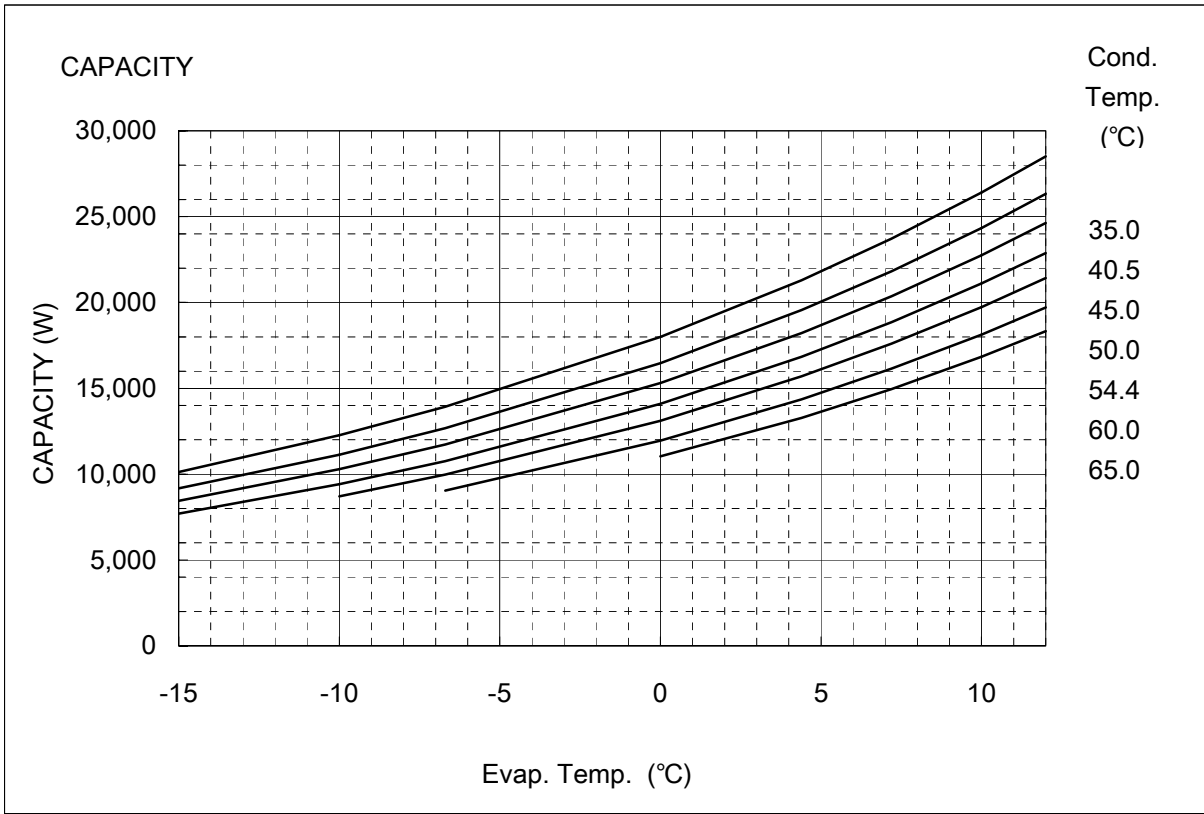

COEFFICIENTS OF PERFORMANCE CURVES

Compressor Model **C-SBN453H8G (809 966 88)**
 Power Source **3PH 50Hz 380-415V**
 Suction Gas Superheat (K) **9**
 Sub Cooling (K) **8.3**
 Compressor Cooling **Natural Cooling**
 Refrigerant **R407C**

$$X=C1+C2*(S)+C3*D+C4*(S2)+C5*(S*D)+C6*(D2)+C7*(S3)+C8*(D*S2)+C9*(S*D2) +C10*(D3)$$

X—CAPACITY(W) OR POWER(W) OR CURRENT(A) OR FLOW(kg/h)

S—EVAPORATING TEMP, °C

D—CONDENSING TEMP, °C

380V-50Hz	CAPACITY (W)	POWER (W)	CURRENT (A)
C1	3.034880E+04	2.721748E+03	4.617993E+00
C2	1.060532E+03	-6.974613E-02	1.557206E-03
C3	-4.182717E+02	-2.743618E+01	-1.328039E-02
C4	1.754255E+01	2.007315E-01	-6.459148E-04
C5	-1.211605E+01	2.468342E-01	4.574345E-04
C6	1.861968E+00	1.541522E+00	2.035840E-03
C7	1.539044E-01	-8.299031E-04	9.746187E-07
C8	-1.161028E-01	-6.813749E-03	1.149685E-05
C9	4.543848E-02	-3.655849E-03	-8.462249E-06
C10	4.773682E-09	-1.035467E-08	-6.685040E-12

Note:The polynomial coefficients subject to change without notice.

PERFORMANCE DATA

Compressor Model(Code)	C-SBN453H8G (809 966 88)
Power Source	3PH 60Hz 440-460V
Suction Gas Superheat(K)	9
Sub Cooling(K)	8.3
Compressor Cooling	Natural Cooling
Refrigerant	R407C

CAPACITY(W)

Condensing Temperature(°C)	Evaporating Temperature(°C)							
	-15	-10	-6.7	0	4.4	7.2	10	12
35.0	12,180	14,730	16,690	21,530	25,450	28,300	31,480	33,960
40.5	11,140	13,500	15,330	19,820	23,470	26,140	29,100	31,430
45.0	10,360	12,570	14,280	18,510	21,950	24,470	27,270	29,470
50.0	9,540	11,600	13,200	17,150	20,370	22,730	25,360	27,420
54.4		10,810	12,310	16,040	19,070	21,300	23,790	25,740
60.0			11,270	14,720	17,540	19,610	21,930	23,750
65.0				13,650	16,300	18,240	20,410	22,120

POWER(W)

Condensing Temperature(°C)	Evaporating Temperature(°C)							
	-15	-10	-6.7	0	4.4	7.2	10	12
35.0	4,440	4,470	4,490	4,540	4,580	4,610	4,640	4,670
40.5	4,970	5,010	5,040	5,100	5,140	5,170	5,200	5,220
45.0	5,470	5,520	5,560	5,630	5,670	5,700	5,730	5,740
50.0	6,090	6,160	6,210	6,290	6,330	6,360	6,380	6,390
54.4		6,790	6,840	6,930	6,980	7,000	7,020	7,030
60.0			7,740	7,840	7,890	7,900	7,920	7,920
65.0				8,740	8,780	8,790	8,800	8,790

CURRENT(A)

Condensing Temperature(°C)	Evaporating Temperature(°C)							
	-15	-10	-6.7	0	4.4	7.2	10	12
35.0	6.8	6.8	6.9	6.9	7.0	7.0	7.0	7.1
40.5	7.5	7.6	7.6	7.7	7.7	7.8	7.8	7.8
45.0	8.2	8.2	8.3	8.4	8.4	8.5	8.5	8.5
50.0	9.0	9.1	9.1	9.3	9.3	9.4	9.4	9.4
54.4		9.9	10.0	10.1	10.2	10.2	10.2	10.2
60.0			11.1	11.3	11.4	11.4	11.4	11.4
65.0				12.4	12.5	12.5	12.5	12.5

NOTE:

- * The performance values subject to change without notice.
- * The performance values are based on MID point method.

Compressor Model(Code)
Power Source

C-SBN453H8G (809 966 88)
3PH 60Hz 440-460V

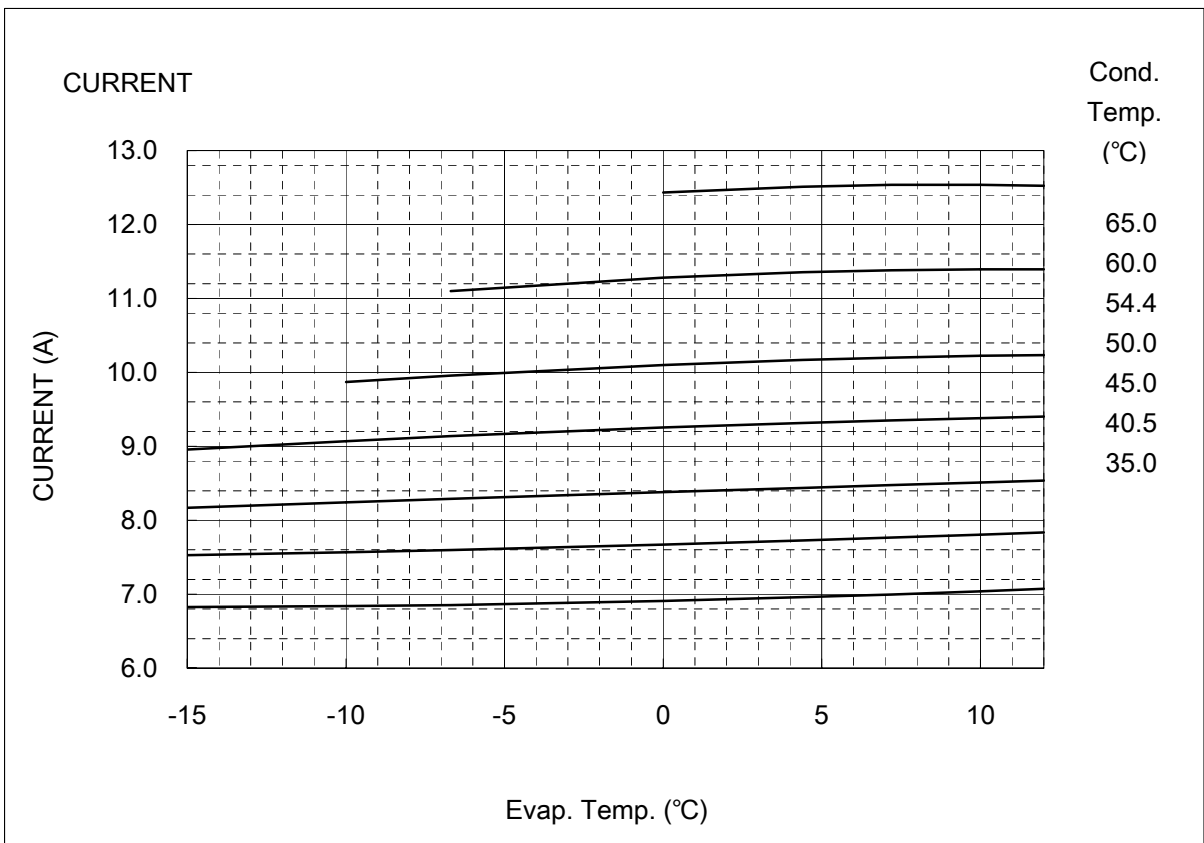
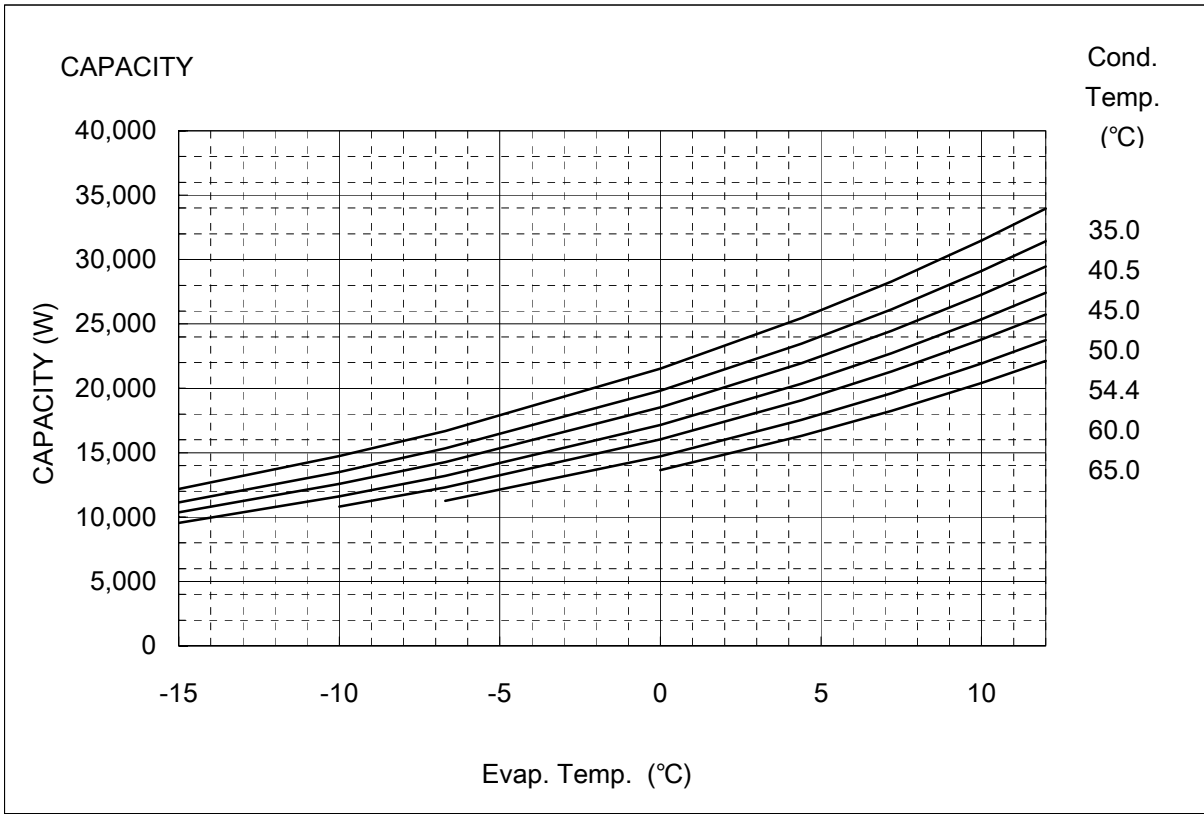

COEFFICIENTS OF PERFORMANCE CURVES

Compressor Model **C-SBN453H8G (809 966 88)**
 Power Source **3PH 60Hz 440-460V**
 Suction Gas Superheat (K) **9**
 Sub Cooling (K) **8.3**
 Compressor Cooling **Natural Cooling**
 Refrigerant **R407C**

$$X=C1+C2*(S)+C3*D+C4*(S^2)+C5*(S*D)+C6*(D^2)+C7*(S^3)+C8*(D*S^2)+C9*(S*D^2) +C10*(D^3)$$

X—CAPACITY(W) OR POWER(W) OR CURRENT(A) OR FLOW(kg/h)

S—EVAPORATING TEMP, °C

D—CONDENSING TEMP, °C

440V-60Hz	CAPACITY (W)	POWER (W)	CURRENT (A)
C1	3.520817E+04	3.139357E+03	4.559524E+00
C2	1.278941E+03	1.164898E+00	2.895240E-03
C3	-4.603243E+02	-1.381666E+01	3.860002E-03
C4	2.137054E+01	1.026872E+00	2.070168E-03
C5	-1.524220E+01	2.799734E-01	1.296189E-04
C6	1.980586E+00	1.536515E+00	1.802690E-03
C7	1.744962E-01	-1.417288E-03	-3.013645E-06
C8	-1.587598E-01	-2.430703E-02	-4.829039E-05
C9	6.140772E-02	-1.690591E-03	2.582662E-06
C10	2.272498E-09	6.056751E-09	1.069223E-11

Note:The polynomial coefficients subject to change without notice.

Section 4. Operating Envelope

Suction Gas
Superheat :9K
Refrigerant : R407C

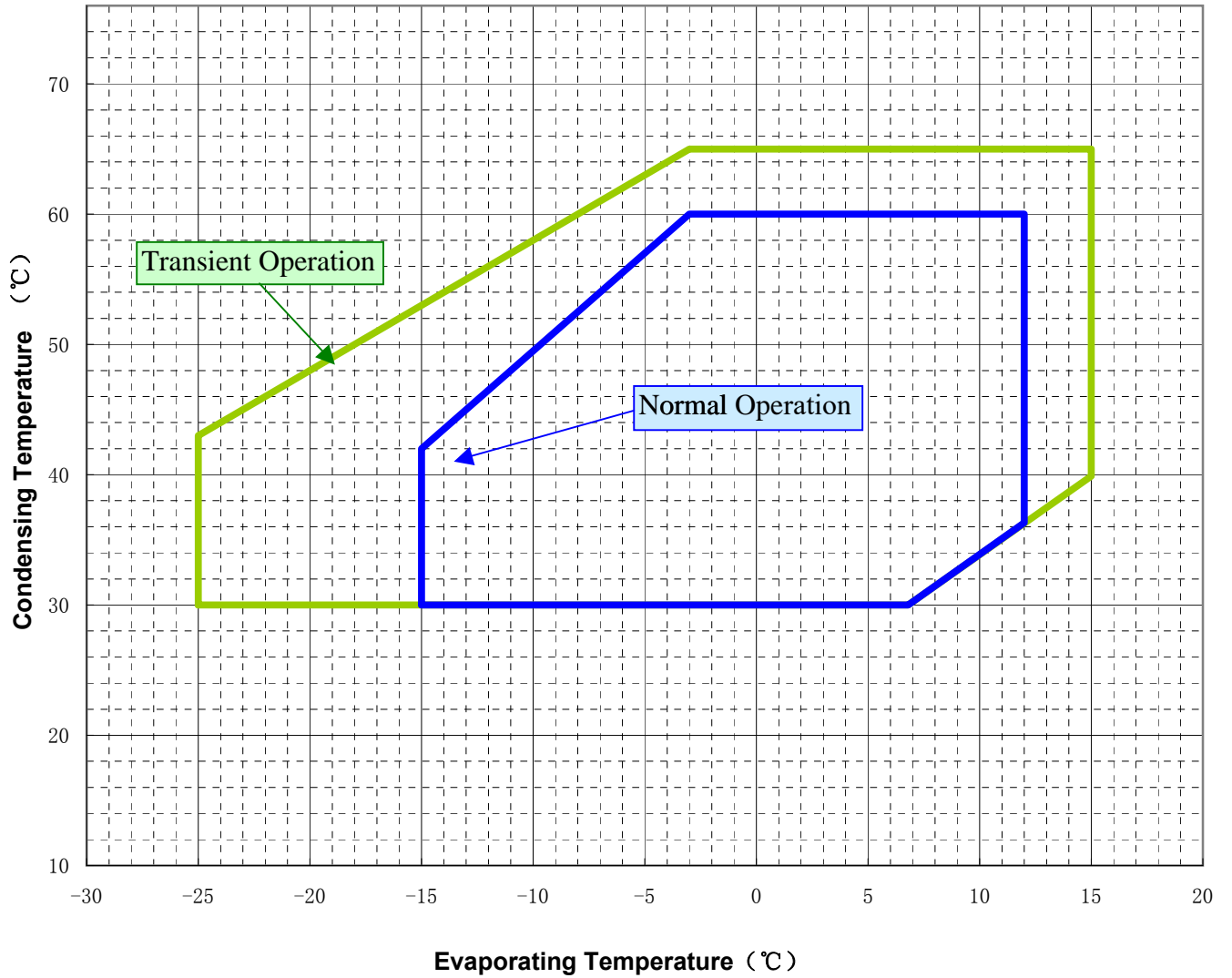

Section 5. Application Standard & Limit

The following requirements apply to vertical type hermetic scroll compressors:

Standard: Applicable to ordinary conditions in Japan JIS B8616 or standards relative to JIS B8616, such as standard rating conditions, maximum operating conditions, low temperature conditions, etc.

Limit: Applicable to transitional brief period of time, such as start-up and beginning of defrost mode.

No.	Item	Standard	Limit	Remark
1	Refrigerant	R407C(Refrigerant must meet a criterion)		
2	Average Evap. Temp.	-15~12°C(5~54 ° F) 0.20~0.65MPa(G)(29~94psig)	-25~15°C(-13~59 ° F) 0.07~0.73MPa(G)(10~106psig)	Average temp. of evaporator Inlet and outlet.
3	Average Cond.Temp.	30~60°C(86~140 ° F) 1.17~2.56MPa(G)(170~371psig)	65°C(149 ° F) 2.88MPa(G)(418psig)	Average temp. of condensor Inlet and outlet.
4	Compression Ratio	2 ~ 6	10	
5	Winding Temp.	115°C(240 °F) Max.	125°C(257 °F)	
6	Shell Bottom Temp.	90°C(194 °F) Max.		
		Evaporating Temp.+12°C(21 °F) Min.		Operating
		Ambient Temp.+11°C(20 °F) Min.		Not Operating
7	Discharge Gas Temp.	115°C(240 °F) Max.	C-SB:130°C(266°F) Max.	Temp. within 10cm of the discharge fitting.
			C-SC:135°C(275°F) Max.	Temp. inside of the copper pipe on the top of compressor
8	Suction Gas Temp.	Superheat: 5K(10 °F)Min.	No excessive noise.	It should meet the requirement of item 5, 6, 7 and 14 within 30cm of the suction fitting.
9	Running Voltage	Within ±10% of the rated voltage		Voltage at compressor terminals.
10	Starting Voltage	Three Phase Models: 85% of the rated voltage min.		Voltage at compressor terminals.
		Single Phase Models: 90% of the rated voltage min.		
11	On/Off Cycling	On Period: Until the oil level returns to the center of the lower bearing Off Period: Until balance of high and low pressure is obtained		For at least 7 minutes - on/3 minutes-off is recommended.
12	Refrigerant Charge	Oil/Refrigerant(wt.)>0.35.		Specific gravity of the Oil:0.94.
13	Life Time	200,000 cycle		
14	Minimum Oil Level	C-SB:Center of the lower bearing	C-SB:Bottom of the lower bearing	
		C-SC:No less than 70% of the initial oil charge		
15	Abnormal Pressure Rise/Drop	Pressure Rise: 3.20MPa(G) (464psig) Max.		By high pressure switch
		Pressure Drop: 0.05MPa(G) (7.3psig) Min.		By low pressure switch
16	System Moisture Level	200ppm Max.		
17	System Uncondensable Gas Level	1 Vol.% Max. Residual Oxygen 0.1 Vol.% Max.		24 hrs. after vacuuming: 1.01kPa Max.
18	Tilt	5Deg.Max.		

(G): Gauge Pressure

Notes

- 1 Installation should be completed within 15 minutes after removing the rubber plugs.
- 2 Do not use the compressor to compress air.
- 3 Do not energize the compressor under vacuumed condition.
- 4 Evacuation and Refrigerant charge : Evacuate internal section in the refrigeration system from high and low pressure sides and charge liquid refrigerant from condenser outlet side. Additional charge shall be done with gas condition from low side.
- 5 Do not tilt over the compressor while carrying it.
- 6 Do not remove the paint.
- 7 Crankcase heater is required when the oil sump temperature is too low to meet the requirement of item 6 on page 7.
- 8 Voltage fluctuation between compressor terminals, during operation, shall be within 2% of the rated voltage.
- 9 Do not operate compressor in reverse rotational direction.
- 10 Suction strainers are recommended for all applications.
- 11 Copper Piping Stress

Start/Shutdown	34.32 N/mm ² Max.
Run	12.26 N/mm ² Max.

Section 6. Selection of Electrical Wire

Voltage drop may occur due to the large current draw during compressor starting.

We recommend selecting the wire size from the table below.

6.1 Type of Unit

6.1.1 Window & Commercial Type Unit

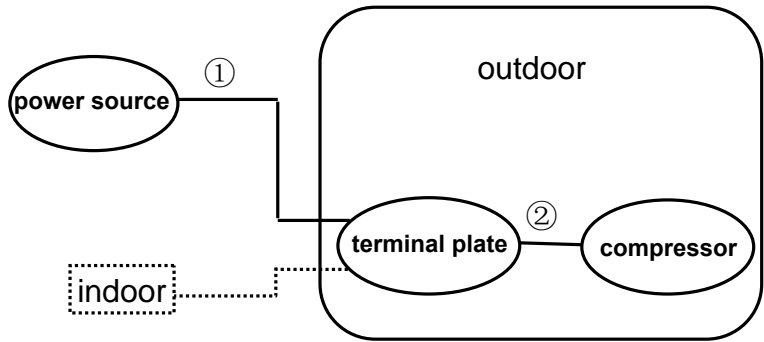

6.1.2 Split Type(Separate Type)

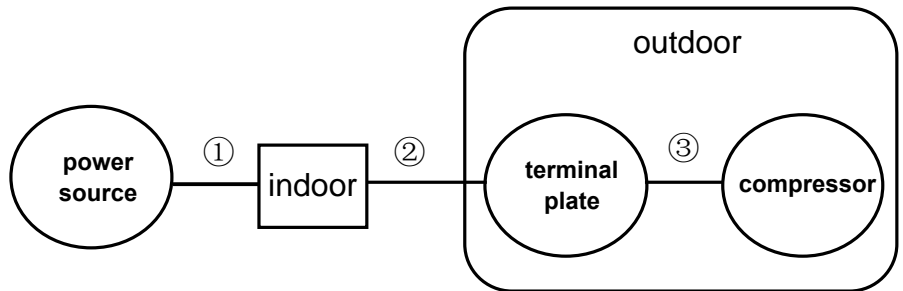

6.2 Size Table of Electrical Wire

Starting current (A)	Size of electrical wire (mm ²)						
	Remark ① or Remark ①+② (heat-resistance Temperature: 60°C(140°F) min.)						Remark③ (heat-resistance Temperature: 120°C(248°F) min.)
	5m max.	10m max.	15m max.	20m max.	30m max.	50m max.	1m max.
20max.	2.0	2.0	2.0	3.5	5.5	8.0	2.0
30max.	↑	↑	3.5	5.5	↑	14.0	↑
40max.	↑	3.5	5.5	↑	8.0	↑	↑
50max.	↑	↑		8.0	14.0	22.0	↑
60max.	↑	5.5	↑	↑			↑
70max.	3.5	↑	8.0	14.0	↑	↑	3.5
80max.	↑	↑			22.0	30.0	↑
90max.	↑	↑	14.0	↑	↑		↑
100max.	↑	8.0	↑	↑		38.0	↑
110max.	↑	↑					↑
120max.	5.5	↑	↑	22.0	30.0	↑	↑
140max.	↑	14.0	↑	↑		50.0	5.5
160max.	↑	↑	22.0	↑	↑		↑
180max.	↑	↑			38.0	60.0	8.0
200max.	8.0	↑	↑	30.0	↑	↑	↑
220max.	↑	↑			50.0	80.0	↑
240max.	↑	↑					14.0

The internal motor protector does not protect the compressor against all possible conditions.

Please be sure that the system utilizes the ground connection when installed in the field.

Section 7. Drawings

7.1. Dimensional Sketch

C-SB Series

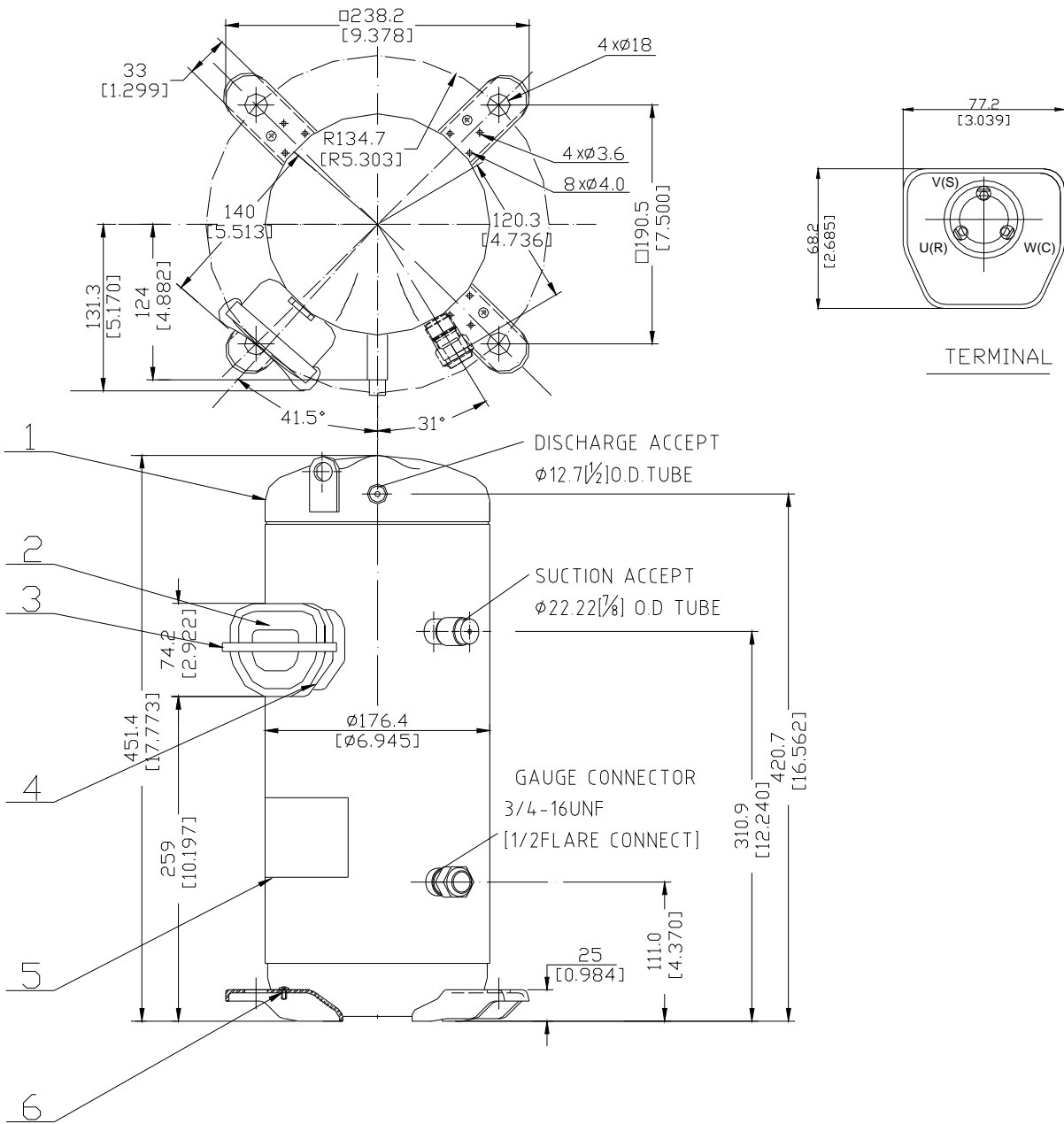

No.	Qty	Name
1	1	Compressor
2	1	Terminal Box Cover
3	1	Terminal Box Clip
4	1	Insulating Grommet
5	1	Nameplate
6	1	Screw Special

7.2. Wiring & mounting sketch

WIRING DIAGRAM C-SB Series 3phase B8

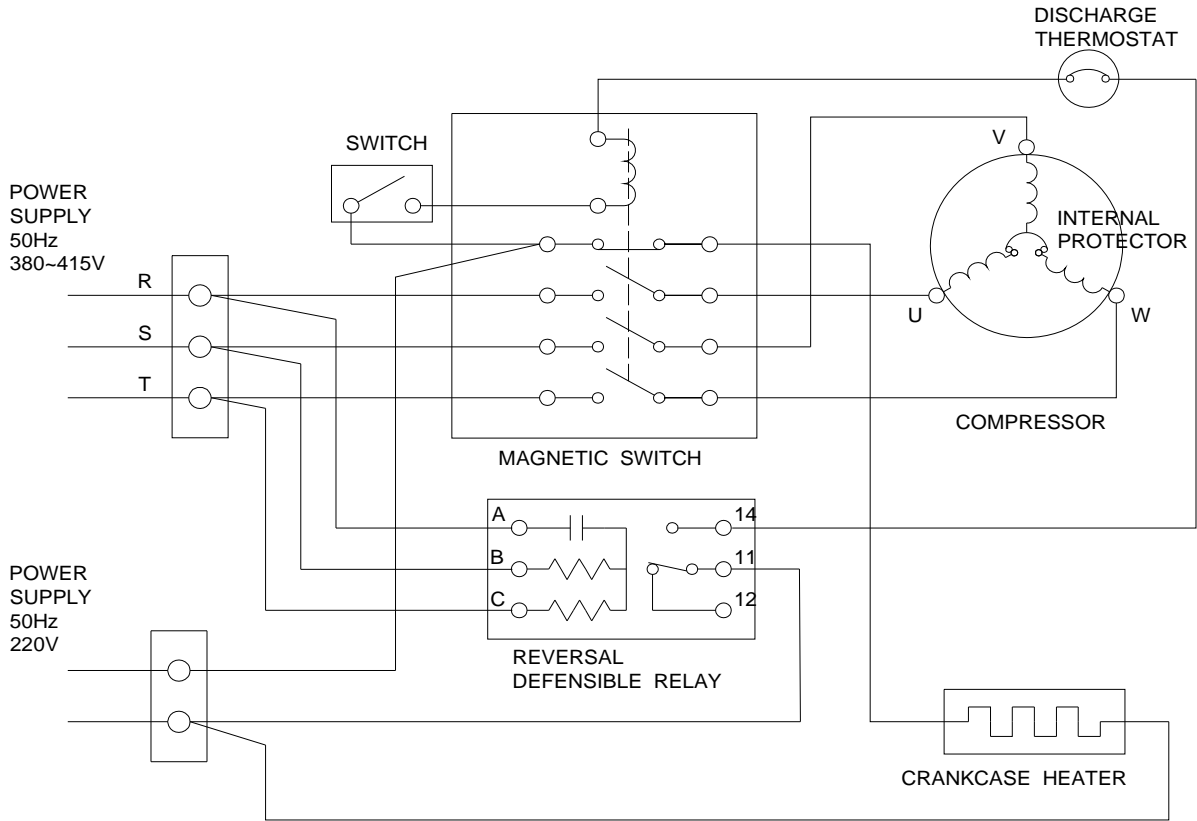

MOUNTING SKETCH

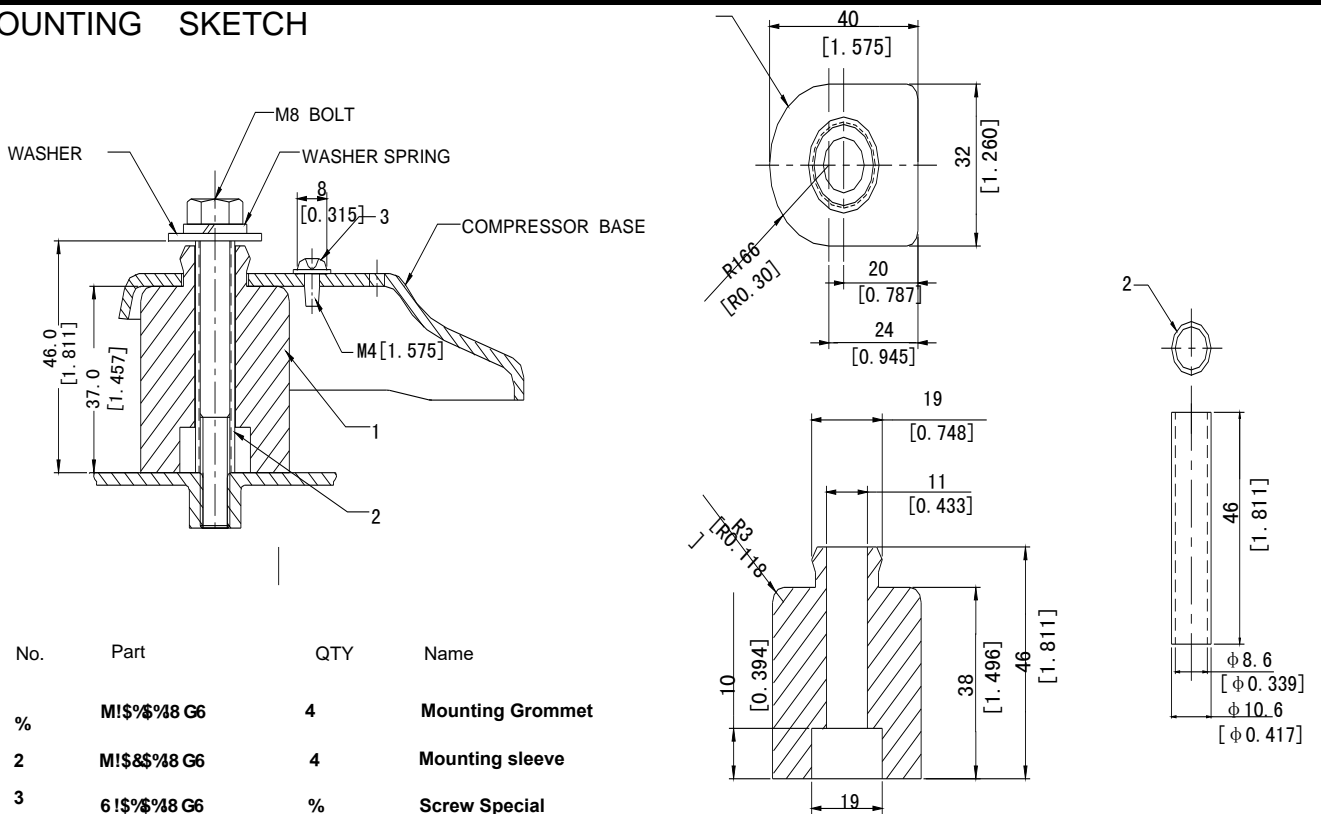

7.2. Packing dimensios

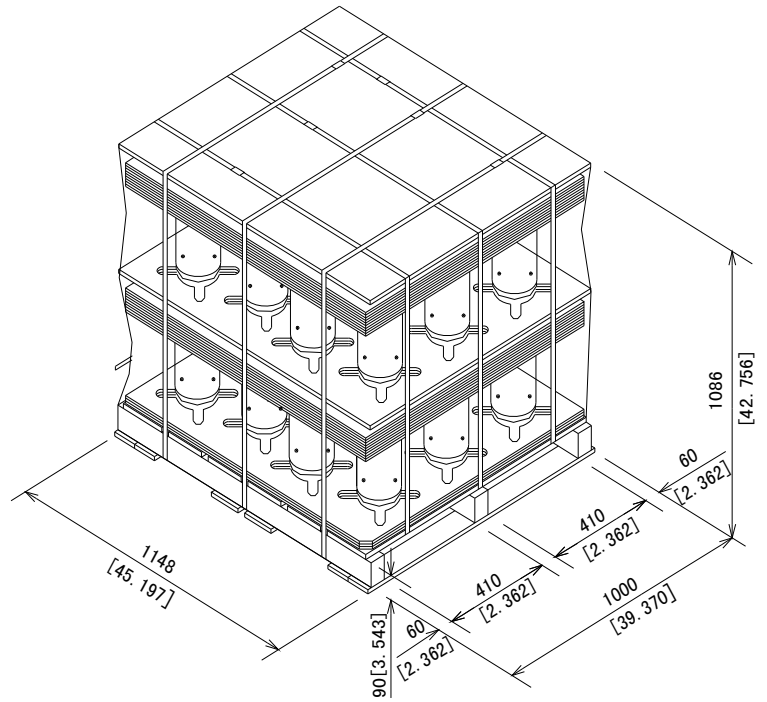
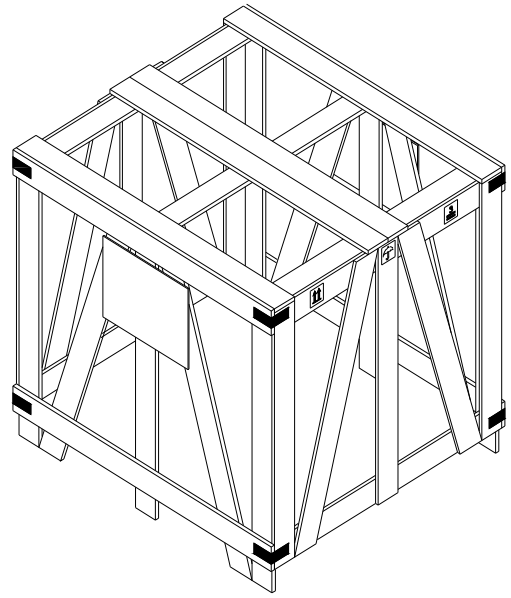
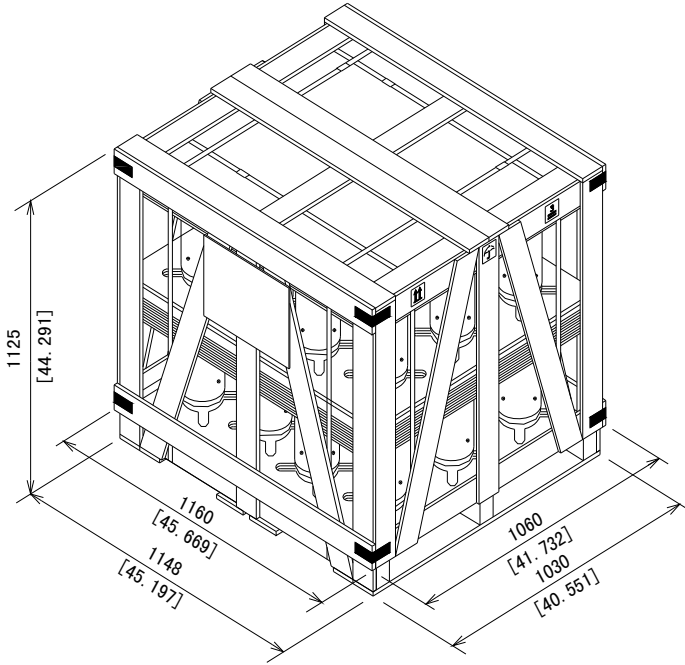

Part Code

D-0201-DSB

Name

Packing Dimensions