

EMT6144Z



**ENGINEERING CODE**  
194PA67

**REFRIGERANT**  
R-134a

**POWER SUPPLY**  
220-240 V 50 Hz

**APPLICATION**  
HBP

**MOTOR TYPE**  
CSIR

**STANDARD**  
EN12900

**COOLING CAPACITY**  
508 W

**EFFICIENCY**  
2.44 W/W

DATA

GENERAL DATA

Model	EMT6144Z
Type	Hermetic Reciprocating
Technology	ON/OFF
Compressor Application	HBP
Expansion Device	Capillary Tube or Expansion Valve
Compressor Cooling	Fan/220
HP	1/5
Starting Torque	HST
Plant	ITALY

ELECTRICAL DATA

Start Winding Resistance	null
Run Winding Resistance	null
Locked Rotor Amperage (LRA) 50Hz	8.5 A

## MECHANICAL DATA

Displacement	5.19 cm <sup>3</sup>
Oil Charge	180 ml
Oil Type	ESTER
Oil Viscosity	ISO22
Weight	7.8 Kg

## ELECTRICAL COMPONENTS

Start Capacitor	43-53 µf/330 V
CSR CSIR BOX	No
Starting Device Type	RELAY
Starting Device Description	MTRP-34*
Overload Protection	T0827/G6

## PERFORMANCE

### TESTED CONDITIONS

Tested Refrigerant	R-134a
Tested Application	HBP
Tested Standard	EN12900
Tested Cooling	Fan
Tested Voltage	220 V
Max Refrigerant Charge	250 g
Refrigerant Temperature	Dew

### RATED POINTS

Condensing Temperature °C	Evaporating Temperature °C	Cooling Capacity W	Efficiency W/W	Power Consumption W	Current A	Gas Flow Rate kg/h
50	5	508	2.44	208	-	12.74

Test Condition: Subcooling 0 K, Return Gas 20 °C. Data are an indication of performance based simulation.

### PERFORMANCE CURVE

Condensing Temperature 35°C

Evaporating Temperature °C	Cooling Capacity W	Efficiency W/W	Power Consumption W	Current A	Gas Flow Rate kg/h
-15	267	2.06	130	-	5.64
-10	335	2.37	141	-	7.14
-5	417	2.70	154	-	8.91
0	511	3.08	166	-	10.99
5	620	3.56	174	-	13.43
10	744	4.20	177	-	16.27

Test Condition: Subcooling 0 K, Return Gas 20 °C. Data are an indication of performance based simulation.

## PERFORMANCE CURVE

Condensing Temperature 45°C

Evaporating Temperature °C	Cooling Capacity W	Efficiency W/W	Power Consumption W	Current A	Gas Flow Rate kg/h
-15	230	1.63	141	-	5.33
-10	291	1.90	153	-	6.78
-5	363	2.16	168	-	8.52
0	448	2.42	185	-	10.58
5	546	2.72	200	-	12.99
10	657	3.08	213	-	15.81

Test Condition: Subcooling 0 K, Return Gas 20 °C. Data are an indication of performance based simulation.

## PERFORMANCE CURVE

Condensing Temperature 55°C

Evaporating Temperature °C	Cooling Capacity W	Efficiency W/W	Power Consumption W	Current A	Gas Flow Rate kg/h
-10	247	1.55	160	-	6.41
-5	310	1.78	175	-	8.10
0	384	1.99	193	-	10.11
5	470	2.21	213	-	12.48
10	569	2.45	233	-	15.26

Test Condition: Subcooling 0 K, Return Gas 20 °C. Data are an indication of performance based simulation.

## ENVELOPE



## External

### EXTERNAL CHARACTERISTICS

Base Plate		SMALL	
Tray Holder		YES	
Connector	Internal Diameter	Shape	Material
Suction	6.1 mm	SLANTED 42°	COPPER
Discharge	4.86 mm	STRAIGHT	COPPER
Process	6.1 mm	SLANTED 42°	COPPER

**EXTERNAL DIMENSIONS**

**SHELL**

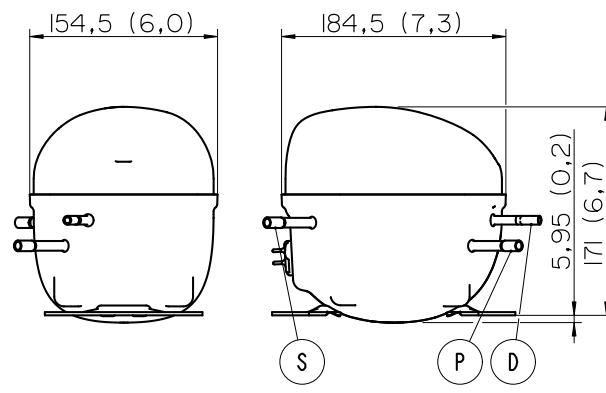

**BASE**

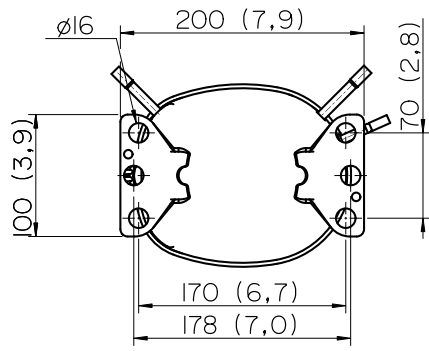

**FENCE**

