

NJ9238GK

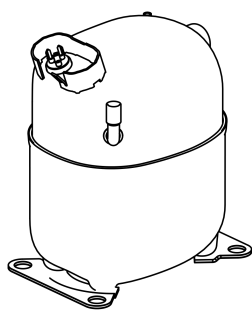

**ENGINEERING CODE**  
943RV95

**REFRIGERANT**  
R-404A

**POWER SUPPLY**  
230 V 50 Hz

**APPLICATION**  
MBP

**MOTOR TYPE**  
CSCR

**STANDARD**  
EN12900

**COOLING CAPACITY**  
2431 W

**EFFICIENCY**  
1.58 W/W



DATA

GENERAL DATA

Model	NJ9238GK
Type	Hermetic Reciprocating
Technology	ON/OFF
Compressor Application	MBP
Expansion Device	Capillary Tube or Expansion Valve
Compressor Cooling	Fan/230
HP	1 1/2
Starting Torque	HST
Plant	SLOVAKIA

ELECTRICAL DATA

Start Winding Resistance	5.46 Ω at 25°C
Run Winding Resistance	1.83 Ω at 25°C
Locked Rotor Amperage (LRA) 50Hz	43 A

## MECHANICAL DATA

Displacement	32.67 cm <sup>3</sup>
Oil Charge	750 ml
Oil Type	ESTER
Oil Viscosity	ISO22
Weight	20.6 Kg

## ELECTRICAL COMPONENTS

Start Capacitor	130-156 µf/330 V
Run Capacitor	25.0 µf/400 V
CSR CSIR BOX	Yes
Starting Device Description	RVA3H3C-108
Overload Protection	T0878/C9 OR MRA3764-

## PERFORMANCE

### TESTED CONDITIONS

Tested Refrigerant	R-404A
Tested Application	MBP
Tested Standard	EN12900
Tested Cooling	Fan
Tested Voltage	230 V
Max Refrigerant Charge	800 g
Refrigerant Temperature	Dew

### RATED POINTS

Condensing Temperature °C	Evaporating Temperature °C	Cooling Capacity W	Efficiency W/W	Power Consumption W	Current A	Gas Flow Rate kg/h
45	-10	2431	1.58	1534	7.43	72.98

Test Condition: Subcooling 0 K, Return Gas 20 °C. Data generated in accordance to EN 12900:2013 polynomial equation and tolerance guidelines.

### PERFORMANCE CURVE

Condensing Temperature 35°C

Evaporating Temperature °C	Cooling Capacity W	Efficiency W/W	Power Consumption W	Current A	Gas Flow Rate kg/h
-20	1898	1.62	1172	6.08	49.20
-15	2414	1.84	1314	6.57	63.08
-10	3000	2.06	1455	7.09	79.09
-5	3648	2.31	1582	7.64	97.18
0	4351	2.59	1682	8.22	117.33

Test Condition: Subcooling 0 K, Return Gas 20 °C. Data generated in accordance to EN 12900:2013 polynomial equation and tolerance guidelines.

## PERFORMANCE CURVE

Condensing Temperature 45°C

Evaporating Temperature °C	Cooling Capacity W	Efficiency W/W	Power Consumption W	Current A	Gas Flow Rate kg/h
-20	1511	1.25	1213	6.20	44.55
-15	1939	1.42	1364	6.79	57.63
-10	2431	1.58	1534	7.43	72.98
-5	2980	1.74	1709	8.10	90.58
0	3579	1.91	1877	8.82	110.39

Test Condition: Subcooling 0 K, Return Gas 20 °C. Data generated in accordance to EN 12900:2013 polynomial equation and tolerance guidelines.

## PERFORMANCE CURVE

Condensing Temperature 55°C

Evaporating Temperature °C	Cooling Capacity W	Efficiency W/W	Power Consumption W	Current A	Gas Flow Rate kg/h
-10	1889	1.20	1569	7.70	66.98
-5	2329	1.32	1763	8.44	83.73
0	2814	1.43	1970	9.23	102.86

Test Condition: Subcooling 0 K, Return Gas 20 °C. Data generated in accordance to EN 12900:2013 polynomial equation and tolerance guidelines.

## ENVELOPE

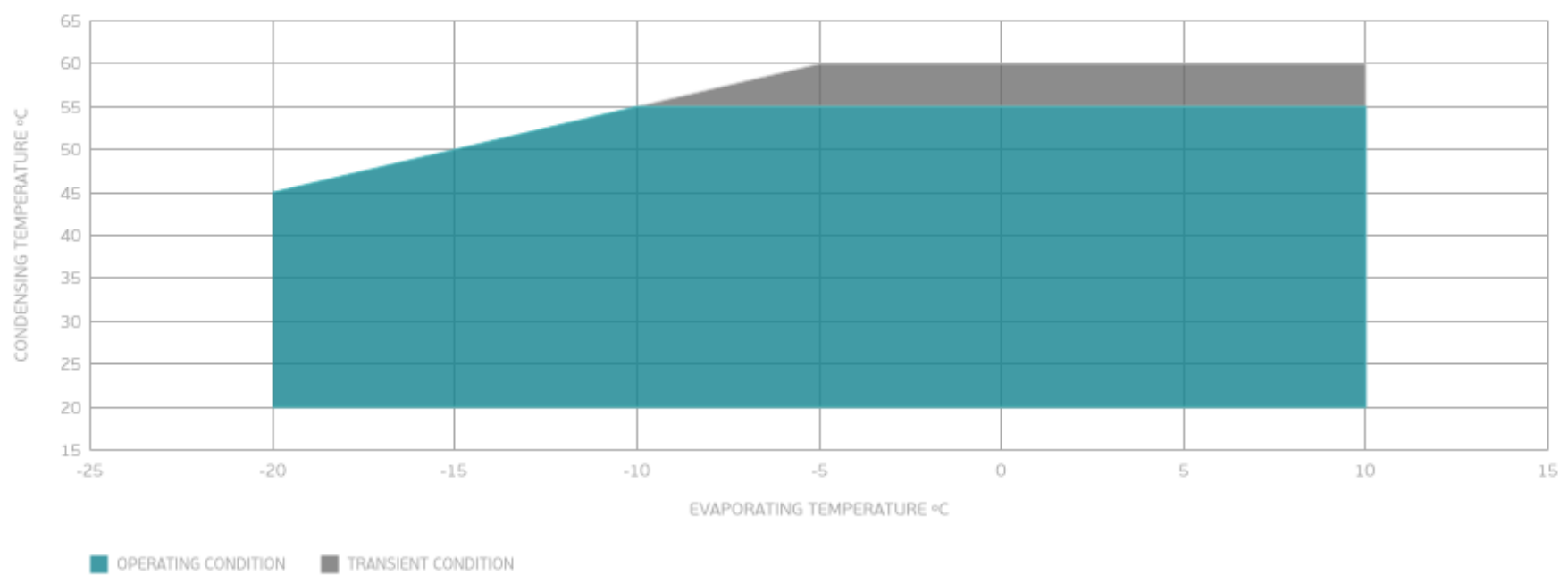

## External

### EXTERNAL CHARACTERISTICS

Base Plate		LARGE	
Tray Holder		NO	
Connector	Internal Diameter	Shape	Material
Suction	12.77 mm	VERTICAL	COPPER
Discharge	8 mm	SLANTED J	COPPER
Process	6.42 mm	VERTICAL	COPPER

## EXTERNAL DIMENSIONS

### SHELL

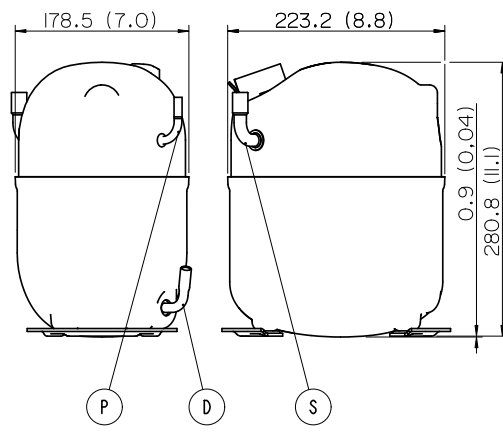

### BASE

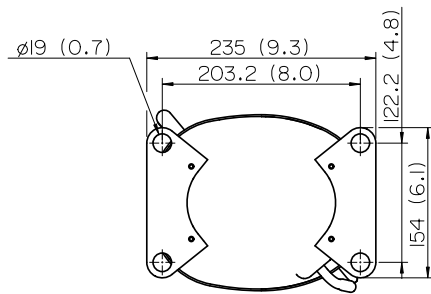

### FENCE

