

NEK6210Z



ENGINEERING CODE
268BA51



REFRIGERANT
R-134a



POWER SUPPLY
220-240 V 50 Hz



APPLICATION
HBP



MOTOR TYPE
CSIR



STANDARD
EN12900



COOLING CAPACITY
1014 W



EFFICIENCY
2.19 W/W



DATA

GENERAL DATA

Model	NEK6210Z
Type	Hermetic Reciprocating
Technology	ON/OFF
Compressor Application	HBP
Expansion Device	Capillary Tube or Expansion Valve
Compressor Cooling	Fan/220
HP	1/3+
Starting Torque	HST
Plant	SLOVAKIA

ELECTRICAL DATA

Start Winding Resistance	31.7 Ω at 25°C
Run Winding Resistance	5.18 Ω at 25°C

MECHANICAL DATA

Displacement	12.11 cm ³
Oil Charge	350 ml
Oil Type	ESTER
Oil Viscosity	ISO22
Weight	11 Kg

ELECTRICAL COMPONENTS

Start Capacitor	53-64 µf/330 V
CSR CSIR BOX	No
Starting Device Type	RELAY
Starting Device Description	MTRP-0029*
Overload Protection	T0660/G5

PERFORMANCE

TESTED CONDITIONS

Tested Refrigerant	R-134a
Tested Application	HBP
Tested Standard	EN12900
Tested Cooling	Fan
Tested Voltage	220 V
Refrigerant Temperature	Dew

RATED POINTS

Condensing Temperature °C	Evaporating Temperature °C	Cooling Capacity W	Efficiency W/W	Power Consumption W	Current A	Gas Flow Rate kg/h
50	5	1014	2.19	464	-	25.45

Test Condition: Subcooling 0 K, Return Gas 20 °C. Data are an indication of performance based simulation.

PERFORMANCE CURVE

Condensing Temperature 35°C

Evaporating Temperature °C	Cooling Capacity W	Efficiency W/W	Power Consumption W	Current A	Gas Flow Rate kg/h
-15	535	2.01	267	-	11.32
-10	667	2.25	297	-	14.19
-5	824	2.50	330	-	17.60
0	1009	2.80	361	-	21.68
5	1226	3.18	386	-	26.57
10	1482	3.69	402	-	32.41

Test Condition: Subcooling 0 K, Return Gas 20 °C. Data are an indication of performance based simulation.

PERFORMANCE CURVE

Condensing Temperature 45°C

Evaporating Temperature °C	Cooling Capacity W	Efficiency W/W	Power Consumption W	Current A	Gas Flow Rate kg/h
-15	456	1.57	290	-	10.58
-10	581	1.80	323	-	13.57
-5	726	2.00	363	-	17.02
0	893	2.20	405	-	21.09
5	1088	2.44	446	-	25.91
10	1316	2.74	480	-	31.62

Test Condition: Subcooling 0 K, Return Gas 20 °C. Data are an indication of performance based simulation.

PERFORMANCE CURVE

Condensing Temperature 55°C

Evaporating Temperature °C	Cooling Capacity W	Efficiency W/W	Power Consumption W	Current A	Gas Flow Rate kg/h
-10	475	1.44	331	-	12.32
-5	610	1.63	374	-	15.90
0	762	1.80	423	-	20.04
5	937	1.98	474	-	24.86
10	1138	2.17	524	-	30.52

Test Condition: Subcooling 0 K, Return Gas 20 °C. Data are an indication of performance based simulation.

ENVELOPE



External

EXTERNAL CHARACTERISTICS

Base Plate		SMALL	
Tray Holder		NO	
Connector	Internal Diameter	Shape	Material
Suction	8.1 mm	SLANTED 42°	COPPER
Discharge	6.1 mm	STRAIGHT	COPPER
Process	6.1 mm	SLANTED 42°	COPPER

EXTERNAL DIMENSIONS

SHELL

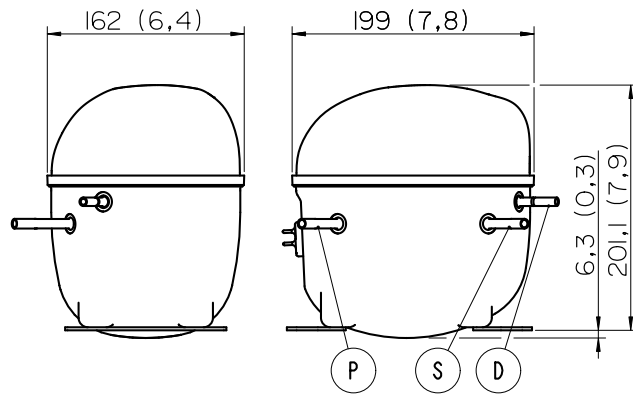

BASE

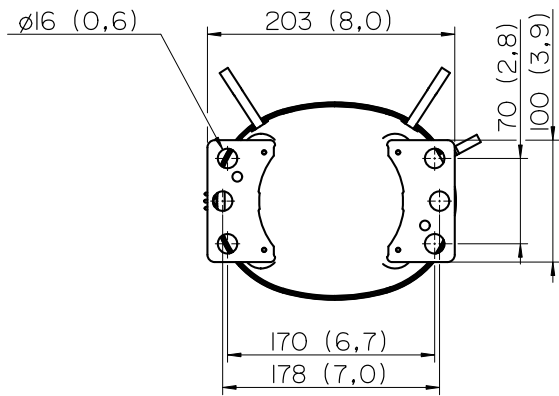

FENCE

