

NEK6210Z



ENGINEERING CODE
269EB51



REFRIGERANT
R-134a



POWER SUPPLY
200-230 V 50
Hz/208-230 V 60
Hz



APPLICATION
HBP



STANDARD
EN12900



MOTOR TYPE
CSIR



COOLING CAPACITY
1069 W



EFFICIENCY
1.92 W/W

DATA

GENERAL DATA

Model	NEK6210Z
Type	Hermetic Reciprocating
Technology	ON/OFF
Compressor Application	HBP
Expansion Device	Capillary Tube or Expansion Valve
Compressor Cooling	Fan/208
HP	1/3+
Starting Torque	HST
Plant	SLOVAKIA

ELECTRICAL DATA

Start Winding Resistance	15.5 Ω at 25°C
Run Winding Resistance	3.2 Ω at 25°C

MECHANICAL DATA

Displacement	12.11 cm ³
Oil Charge	350 ml
Oil Type	ESTER
Oil Viscosity	ISO22
Weight	11.6 Kg

ELECTRICAL COMPONENTS

Start Capacitor	64-77 µf/330 V
CSR CSIR BOX	No
Starting Device Type	RELAY
Starting Device Description	MTRP-0012*
Overload Protection	MST22AKK-3259

PERFORMANCE

TESTED CONDITIONS

Tested Refrigerant	R-134a
Tested Application	HBP
Tested Standard	EN12900
Tested Cooling	Fan
Tested Voltage	208 V
Refrigerant Temperature	Dew

RATED POINTS

Condensing Temperature °C	Evaporating Temperature °C	Cooling Capacity W	Efficiency W/W	Power Consumption W	Current A	Gas Flow Rate kg/h
50	5	1069	1.92	556	-	26.83

Test Condition: Subcooling 0 K, Return Gas 20 °C. Data are an indication of performance based simulation.

PERFORMANCE CURVE

Condensing Temperature 35°C

Evaporating Temperature °C	Cooling Capacity W	Efficiency W/W	Power Consumption W	Current A	Gas Flow Rate kg/h
-15	610	1.89	323	-	12.89
-10	702	2.03	346	-	14.97
-5	837	2.19	383	-	17.89
0	1037	2.42	428	-	22.26
5	1325	2.76	480	-	28.69
10	1725	3.24	533	-	37.79

Test Condition: Subcooling 0 K, Return Gas 20 °C. Data are an indication of performance based simulation.

PERFORMANCE CURVE

Condensing Temperature 45°C

Evaporating Temperature °C	Cooling Capacity W	Efficiency W/W	Power Consumption W	Current A	Gas Flow Rate kg/h
-15	526	1.48	354	-	12.21
-10	606	1.62	373	-	14.14
-5	722	1.75	413	-	16.93
0	897	1.91	470	-	21.17
5	1155	2.13	542	-	27.50
10	1518	2.43	623	-	36.52

Test Condition: Subcooling 0 K, Return Gas 20 °C. Data are an indication of performance based simulation.

PERFORMANCE CURVE

Condensing Temperature 55°C

Evaporating Temperature °C	Cooling Capacity W	Efficiency W/W	Power Consumption W	Current A	Gas Flow Rate kg/h
-10	514	1.35	381	-	13.31
-5	609	1.46	416	-	15.90
0	758	1.59	478	-	19.96
5	983	1.75	561	-	26.12
10	1307	1.97	662	-	34.99

Test Condition: Subcooling 0 K, Return Gas 20 °C. Data are an indication of performance based simulation.

ENVELOPE



External

EXTERNAL CHARACTERISTICS

Base Plate		SMALL	
Tray Holder		NO	
Connector	Internal Diameter	Shape	Material
Suction	8.1 mm	SLANTED 42°	COPPER
Discharge	6.1 mm	STRAIGHT	COPPER
Process	6.1 mm	SLANTED 42°	COPPER

EXTERNAL DIMENSIONS

SHELL

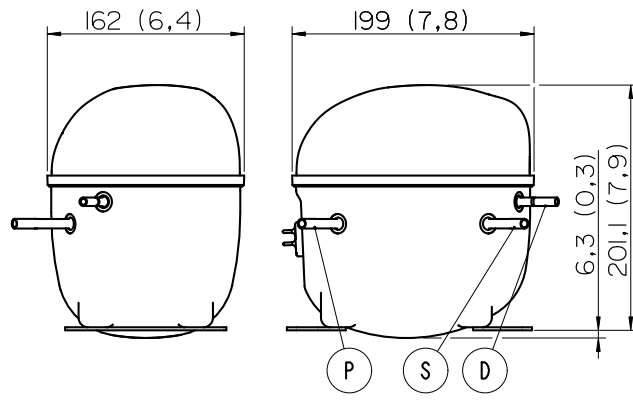

BASE

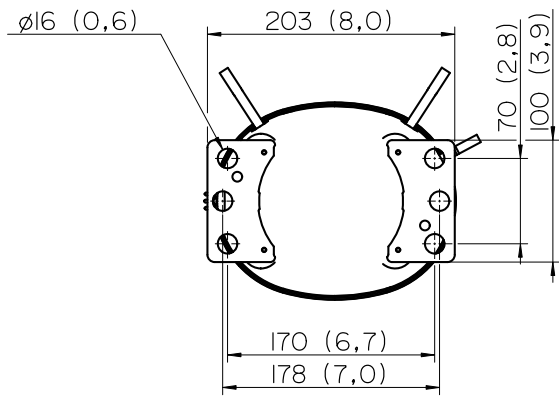

FENCE

