

NEK2134GK



ENGINEERING CODE
954JD71



REFRIGERANT
R-404A



POWER SUPPLY
208-230 V 60 Hz



APPLICATION
LBP



MOTOR TYPE
CSIR



STANDARD
EN12900



COOLING CAPACITY
290 W



EFFICIENCY
1.01 W/W



DATA

GENERAL DATA

Model	NEK2134GK
Type	Hermetic Reciprocating
Technology	ON/OFF
Compressor Application	LBP
Expansion Device	Capillary Tube or Expansion Valve
Compressor Cooling	Fan/208
HP	1/2
Starting Torque	HST
Plant	SLOVAKIA

ELECTRICAL DATA

Start Winding Resistance	15.1 Ω at 25°C
Run Winding Resistance	4.8 Ω at 25°C
Locked Rotor Amperage (LRA) 60Hz	20 A

MECHANICAL DATA

Displacement	8.77 cm ³
Oil Charge	350 ml
Oil Type	ESTER
Oil Viscosity	ISO22
Weight	10.7 Kg

ELECTRICAL COMPONENTS

Start Capacitor	64-77 µf/330 V
CSR CSIR BOX	No
Starting Device Type	RELAY
Starting Device Description	MTRP-49*
Overload Protection	MRA38171-3265

PERFORMANCE

TESTED CONDITIONS

Tested Refrigerant	R-404A
Tested Application	LBP
Tested Standard	EN12900
Tested Cooling	Fan
Tested Voltage	208 V
Refrigerant Temperature	Dew

RATED POINTS

Condensing Temperature °C	Evaporating Temperature °C	Cooling Capacity W	Efficiency W/W	Power Consumption W	Current A	Gas Flow Rate kg/h
40	-35	290	1.01	288	-	7.86

Test Condition: Subcooling 0 K, Return Gas 20 °C. Data are an indication of performance based simulation.

PERFORMANCE CURVE

Condensing Temperature 35°C

Evaporating Temperature °C	Cooling Capacity W	Efficiency W/W	Power Consumption W	Current A	Gas Flow Rate kg/h
-40	240	0.98	245	-	6.11
-35	321	1.13	283	-	8.21
-30	420	1.30	324	-	10.77
-25	538	1.47	365	-	13.85
-20	675	1.67	405	-	17.49
-15	832	1.87	444	-	21.73
-10	1010	2.11	479	-	26.62

Test Condition: Subcooling 0 K, Return Gas 20 °C. Data are an indication of performance based simulation.

PERFORMANCE CURVE

Condensing Temperature 45°C

Evaporating Temperature °C	Cooling Capacity W	Efficiency W/W	Power Consumption W	Current A	Gas Flow Rate kg/h
-40	192	0.78	245	-	5.53
-35	260	0.90	290	-	7.51
-30	343	1.02	338	-	9.97
-25	443	1.14	388	-	12.97
-20	561	1.28	439	-	16.53
-15	696	1.42	490	-	20.70
-10	849	1.57	540	-	25.53

Test Condition: Subcooling 0 K, Return Gas 20 °C. Data are an indication of performance based simulation.

PERFORMANCE CURVE

Condensing Temperature 55°C

Evaporating Temperature °C	Cooling Capacity W	Efficiency W/W	Power Consumption W	Current A	Gas Flow Rate kg/h
-30	267	0.79	337	-	9.11
-25	348	0.88	395	-	11.98
-20	445	0.97	456	-	15.42
-15	556	1.07	519	-	19.50
-10	685	1.18	582	-	24.24

Test Condition: Subcooling 0 K, Return Gas 20 °C. Data are an indication of performance based simulation.

ENVELOPE



External

EXTERNAL CHARACTERISTICS

Base Plate		UNI	
Tray Holder		NO	
Connector	Internal Diameter	Shape	Material
Suction	8.1 mm	SLANTED 42°	COPPER
Discharge	6.45 mm	STRAIGHT	COPPER

EXTERNAL DIMENSIONS

SHELL



BASE

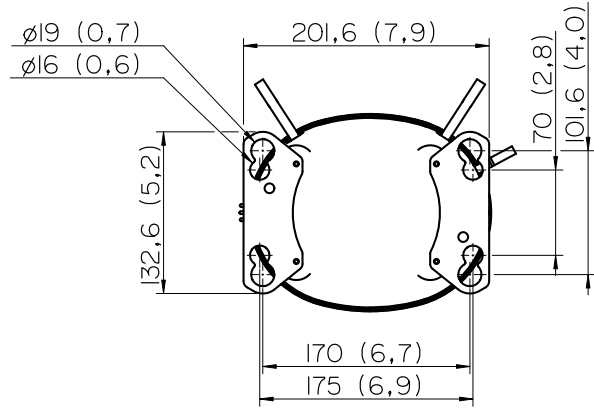

FENCE

