

NEU2140GK



**ENGINEERING CODE**  
958JA51



**REFRIGERANT**  
R-404A



**POWER SUPPLY**  
220-240 V 50 Hz



**APPLICATION**  
LBP



**MOTOR TYPE**  
CSIR



**STANDARD**  
EN12900



**COOLING CAPACITY**  
266 W



**EFFICIENCY**  
1.1 W/W

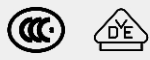

DATA

GENERAL DATA

Model	NEU2140GK
Type	Hermetic Reciprocating
Technology	ON/OFF
Compressor Application	LBP
Expansion Device	Capillary Tube or Expansion Valve
Compressor Cooling	Fan/220
HP	1/2
Starting Torque	HST
Plant	SLOVAKIA

ELECTRICAL DATA

Start Winding Resistance	24.26 Ω at 25°C
Run Winding Resistance	7.79 Ω at 25°C
Locked Rotor Amperage (LRA) 50Hz	13.5 A
Rated Load Amperage (LMBP) at 50 Hz	2.6 A

## MECHANICAL DATA

Displacement	8.77 cm <sup>3</sup>
Oil Charge	350 ml
Oil Type	ESTER
Oil Viscosity	ISO22
Weight	10.6 Kg

## ELECTRICAL COMPONENTS

Start Capacitor	64-77 µf/330 V
CSR CSIR BOX	No
Starting Device Type	RELAY
Starting Device Description	MTRPH-0025-65*
Overload Protection	4TM757JDB MST38AMK-3259 PROTECTOR DRB210J52A

## PERFORMANCE

### TESTED CONDITIONS

Tested Refrigerant	R-404A
Tested Application	LBP
Tested Standard	EN12900
Tested Cooling	Fan
Tested Voltage	220 V
Refrigerant Temperature	Dew

### RATED POINTS

Condensing Temperature °C	Evaporating Temperature °C	Cooling Capacity W	Efficiency W/W	Power Consumption W	Current A	Gas Flow Rate kg/h
40	-35	266	1.1	241	-	7.21

Test Condition: Subcooling 0 K, Return Gas 20 °C. Data are an indication of performance based simulation.

### PERFORMANCE CURVE

Condensing Temperature 35°C

Evaporating Temperature °C	Cooling Capacity W	Efficiency W/W	Power Consumption W	Current A	Gas Flow Rate kg/h
-40	220	1.07	205	-	5.58
-35	292	1.23	237	-	7.46
-30	381	1.41	271	-	9.77
-25	488	1.61	304	-	12.57
-20	613	1.82	337	-	15.89
-15	757	2.05	368	-	19.78
-10	921	2.31	398	-	24.27

Test Condition: Subcooling 0 K, Return Gas 20 °C. Data are an indication of performance based simulation.

## PERFORMANCE CURVE

Condensing Temperature 45°C

Evaporating Temperature °C	Cooling Capacity W	Efficiency W/W	Power Consumption W	Current A	Gas Flow Rate kg/h
-40	177	0.85	208	-	5.09
-35	239	0.98	244	-	6.92
-30	315	1.11	283	-	9.17
-25	406	1.25	325	-	11.89
-20	513	1.39	368	-	15.12
-15	636	1.54	412	-	18.90
-10	775	1.70	456	-	23.28

Test Condition: Subcooling 0 K, Return Gas 20 °C. Data are an indication of performance based simulation.

## PERFORMANCE CURVE

Condensing Temperature 55°C

Evaporating Temperature °C	Cooling Capacity W	Efficiency W/W	Power Consumption W	Current A	Gas Flow Rate kg/h
-30	246	0.85	290	-	8.38
-25	321	0.95	338	-	11.02
-20	408	1.05	389	-	14.16
-15	509	1.15	444	-	17.83
-10	624	1.25	501	-	22.09

Test Condition: Subcooling 0 K, Return Gas 20 °C. Data are an indication of performance based simulation.

## ENVELOPE



## External

### EXTERNAL CHARACTERISTICS

Base Plate		SMALL	
Tray Holder		NO	
<b>Connector</b>	<b>Internal Diameter</b>	<b>Shape</b>	<b>Material</b>
Suction	8.1 mm	SLANTED 42°	COPPER
Discharge	6.1 mm	STRAIGHT	COPPER

EXTERNAL DIMENSIONS

SHELL

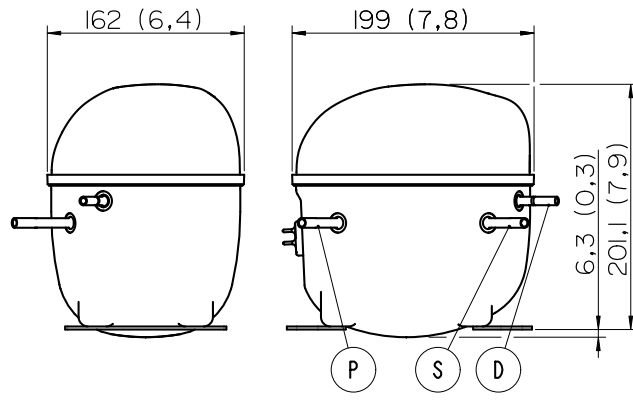

BASE



FENCE

