

EMT45HDR

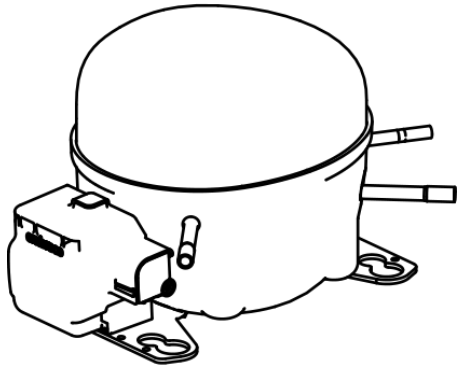

ENGINEERING CODE
194LA47

REFRIGERANT
R-134a

POWER SUPPLY
220-240 V 50 Hz

APPLICATION
HBP

MOTOR TYPE
CSIR

STANDARD
EN12900

COOLING CAPACITY
373 W

EFFICIENCY
2.5 W/W

DATA

GENERAL DATA

Model	EMT45HDR
Type	Hermetic Reciprocating
Technology	ON/OFF
Compressor Application	HBP
Expansion Device	Capillary Tube or Expansion Valve
Compressor Cooling	Static/220
HP	1/7
Starting Torque	HST
Plant	ITALY

ELECTRICAL DATA

Start Winding Resistance	18.1 Ω at 25°C
Run Winding Resistance	16.25 Ω at 25°C
Locked Rotor Amperage (LRA) 50Hz	8.8 A
Rated Load Amperage (LMBP) at 50 Hz	1.2 A
Rated Load Amperage (HBP) at 50 Hz	1.4 A

MECHANICAL DATA

Displacement	3.97 cm ³
Oil Charge	180 ml
Oil Type	ESTER
Oil Viscosity	ISO10
Weight	7.7 Kg

ELECTRICAL COMPONENTS

Start Capacitor	64-77 µf/280 V
CSR CSIR BOX	No
Starting Device Type	RELAY
Starting Device Description	MTRP-0036*
Overload Protection	T0043/G6

PERFORMANCE

TESTED CONDITIONS

Tested Refrigerant	R-134a
Tested Application	HBP
Tested Standard	EN12900
Tested Cooling	Static
Tested Voltage	220 V
Max Refrigerant Charge	250 g
Refrigerant Temperature	Dew

RATED POINTS

Condensing Temperature °C	Evaporating Temperature °C	Cooling Capacity W	Efficiency W/W	Power Consumption W	Current A	Gas Flow Rate kg/h
50	5	373	2.5	149	-	9.36

Test Condition: Subcooling 0 K, Return Gas 20 °C. Data are an indication of performance based simulation.

PERFORMANCE CURVE

Condensing Temperature 35°C

Evaporating Temperature °C	Cooling Capacity W	Efficiency W/W	Power Consumption W	Current A	Gas Flow Rate kg/h
-15	195	2.01	97	-	4.13
-10	244	2.31	105	-	5.18
-5	301	2.65	114	-	6.44
0	369	3.05	121	-	7.93
5	448	3.59	125	-	9.71
10	541	4.33	125	-	11.84

Test Condition: Subcooling 0 K, Return Gas 20 °C. Data are an indication of performance based simulation.

PERFORMANCE CURVE

Condensing Temperature 45°C

Evaporating Temperature °C	Cooling Capacity W	Efficiency W/W	Power Consumption W	Current A	Gas Flow Rate kg/h
-15	169	1.64	103	-	3.93
-10	213	1.90	112	-	4.97
-5	265	2.16	123	-	6.21
0	326	2.44	134	-	7.70
5	398	2.78	144	-	9.49
10	483	3.20	151	-	11.61

Test Condition: Subcooling 0 K, Return Gas 20 °C. Data are an indication of performance based simulation.

PERFORMANCE CURVE

Condensing Temperature 55°C

Evaporating Temperature °C	Cooling Capacity W	Efficiency W/W	Power Consumption W	Current A	Gas Flow Rate kg/h
-10	183	1.58	116	-	4.75
-5	229	1.81	127	-	5.97
0	283	2.03	140	-	7.45
5	348	2.27	153	-	9.23
10	424	2.56	166	-	11.36

Test Condition: Subcooling 0 K, Return Gas 20 °C. Data are an indication of performance based simulation.

ENVELOPE



External

EXTERNAL CHARACTERISTICS

Base Plate		SMALL	
Tray Holder		YES	
Connector	Internal Diameter	Shape	Material
Suction	6.1 mm	SLANTED 42°	COPPER
Discharge	4.86 mm	STRAIGHT	COPPER
Process	6.1 mm	SLANTED 42°	COPPER

EXTERNAL DIMENSIONS

SHELL

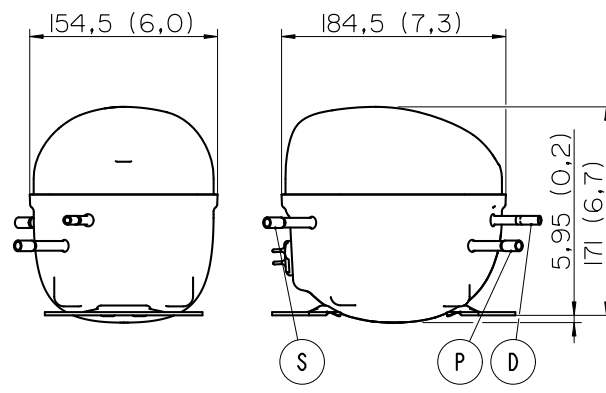

BASE

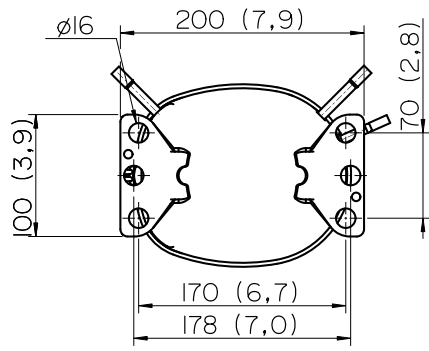

FENCE

