

EMU5125Y



ENGINEERING CODE
876AA67

REFRIGERANT
R-600a

POWER SUPPLY
220-240 V 50 Hz

APPLICATION
HBP

MOTOR TYPE
RSIR/RSCR

STANDARD
EN12900

COOLING CAPACITY
236 W

EFFICIENCY
2.69 W/W

DATA

GENERAL DATA

Model	EMU5125Y
Type	Hermetic Reciprocating
Technology	ON/OFF
Compressor Application	HBP
Expansion Device	Capillary Tube
Compressor Cooling	Static/220
HP	1/10
Starting Torque	LST
Plant	ITALY

ELECTRICAL DATA

Start Winding Resistance	33.1 Ω at 25°C
Run Winding Resistance	39.4 Ω at 25°C
Locked Rotor Amperage (LRA) 50Hz	3.7 A

MECHANICAL DATA

Displacement	4.5 cm ³
Oil Charge	180 ml
Oil Type	ALQUILB
Oil Viscosity	ISO5
Weight	7 Kg

ELECTRICAL COMPONENTS

Run Capacitor	3.0 µf/440 V
CSR CSIR BOX	No
Starting Device Type	PTC
Starting Device Description	V230
Overload Protection	AE37FN

PERFORMANCE

TESTED CONDITIONS

Tested Refrigerant	R-600a
Tested Application	HBP
Tested Standard	EN12900
Tested Cooling	Static
Tested Voltage	220 V
Max Refrigerant Charge	150 g
Refrigerant Temperature	Dew

RATED POINTS

Condensing Temperature °C	Evaporating Temperature °C	Cooling Capacity W	Efficiency W/W	Power Consumption W	Current A	Gas Flow Rate kg/h
50	5	236	2.69	88	-	3.22

Test Condition: Subcooling 0 K, Return Gas 20 °C. Data are an indication of performance based simulation.

PERFORMANCE CURVE

Condensing Temperature 35°C

Evaporating Temperature °C	Cooling Capacity W	Efficiency W/W	Power Consumption W	Current A	Gas Flow Rate kg/h
-15	124	2.11	59	-	1.45
-10	155	2.47	63	-	1.83
-5	192	2.88	67	-	2.27
0	235	3.38	69	-	2.78
5	283	4.02	71	-	3.37
10	338	4.91	69	-	4.04

Test Condition: Subcooling 0 K, Return Gas 20 °C. Data are an indication of performance based simulation.

PERFORMANCE CURVE

Condensing Temperature 45°C

Evaporating Temperature °C	Cooling Capacity W	Efficiency W/W	Power Consumption W	Current A	Gas Flow Rate kg/h
-15	108	1.68	64	-	1.38
-10	136	1.97	69	-	1.75
-5	170	2.28	74	-	2.18
0	208	2.62	79	-	2.69
5	252	3.02	83	-	3.28
10	302	3.53	86	-	3.95

Test Condition: Subcooling 0 K, Return Gas 20 °C. Data are an indication of performance based simulation.

PERFORMANCE CURVE

Condensing Temperature 55°C

Evaporating Temperature °C	Cooling Capacity W	Efficiency W/W	Power Consumption W	Current A	Gas Flow Rate kg/h
-10	117	1.61	72	-	1.65
-5	146	1.87	78	-	2.08
0	181	2.13	85	-	2.58
5	220	2.41	91	-	3.16
10	265	2.75	96	-	3.83

Test Condition: Subcooling 0 K, Return Gas 20 °C. Data are an indication of performance based simulation.

ENVELOPE



External

EXTERNAL CHARACTERISTICS

Base Plate		SMALL	
Tray Holder		YES	
Connector	Internal Diameter	Shape	Material
Suction	6.1 mm	SLANTED 42°	COPPER
Discharge	4.94 mm	STRAIGHT	COPPER
Process	6.1 mm	SLANTED 42°	COPPER

EXTERNAL DIMENSIONS

SHELL

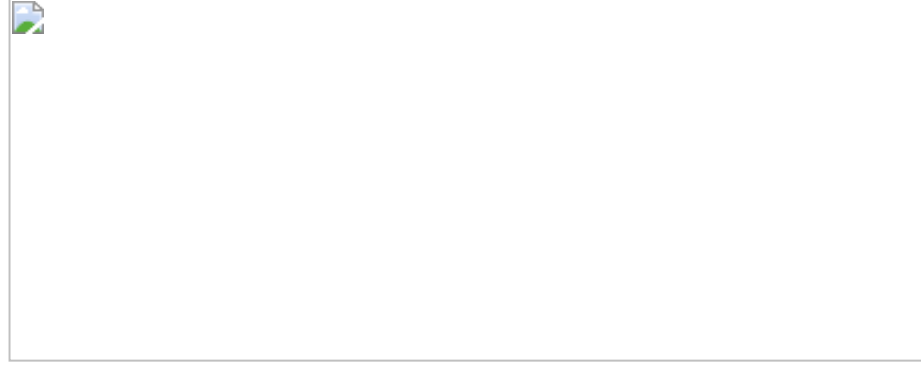

BASE

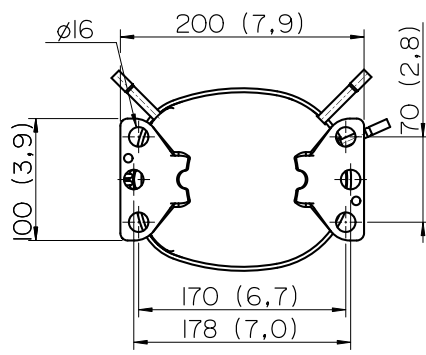

FENCE

