

## Model

Designation	<b>DLE7.5CN</b>	220-240V/50Hz 1~	Sales code:	<b>102H4827</b>
-------------	-----------------	------------------	-------------	-----------------

## Compressor design

Oil type	Polyolester	Refrigerant(s)	<b>R290</b>
Oil viscosity	32cSt	Displacement	7,48cm <sup>3</sup> / 0,46cu.in
Oil quantity	221cm <sup>3</sup> / 7,5fl.oz	Compressors on pallet	80
Refr. charge - tech. limit	150g / 5,3oz		
Free gas volume comp.	1325cm <sup>3</sup> / 44,8fl.oz		
Weight	8,7kg / 19,2lbs		
Motor protection	1# internal		
Winding resistance main	10,91Ω (at 25°C)		
Winding resistance aux	8,34Ω (at 25°C)		
Max. winding temp.	125°C / 257°F		
Max. discharge temp.	125°C / 257°F		



## General - Configurations with DLE7.5CN

Conf. 1	
Motorconfiguration	RSIR
Power supply (nominal)	220-240V/50Hz
Number of phases	1
Voltage range	198-254V
Approvals	VDE, CCC
Starting torque	LST
Note	Electrical equipment is included and pre-assembled to compressor.

## Applications with DLE7.5CN

Conf. 1	
Refrigerant	R290
Application	LBP+MBP
System cooling	fan 3m/s
Hot gas defrost	OK
Long interval pull down	OK

## Electrical data - Configurations with DLE7.5CN

Conf. 1	
Starting device type	PTC
Run capacitor	-/-
Start capacitor	-/-
LRA (locked rotor amps / 4s)	9,18A
RLA (rated load amps / 1s)	1,86A
Cut in current	14,5A
IP class	21

## Model

Designation

**DLE7.5CN**

220-240V/50Hz 1~

Sales code:

**102H4827**

## Compressor dimensions

Housing	A Height	174mm / 6,85in
	B Height	168mm / 6,61in
	C Length shell	183mm / 7,2in
	D Length w. cover	232mm / 9,13in
	E Width	156mm / 6,14in

Connectors		Suction	Discharge	Process
		X	Y	Z
Diameter	[mm]	øi 6,11-6,29	øi 5,12-5,22	øi 4,3-4,6
(i:inside, o:outside)	[in]	øi 0,24-0,25	øi 0,2-0,21	øi 0,17-0,18
Material		copper	copper	copper
Horizontal angle	±2°	10°	0°	0°
Vertical angle	±2°	18°	25°	119°
Position l/h/w	[mm]	127/74/66	98/96/72	-98/133/73
	[in]	5/2,9/2,6	3,8/3,8/2,8	-3,9/5,2/2,9
Straight tube l.	[mm]	12	12	12
	[in]	0,5	0,5	0,5

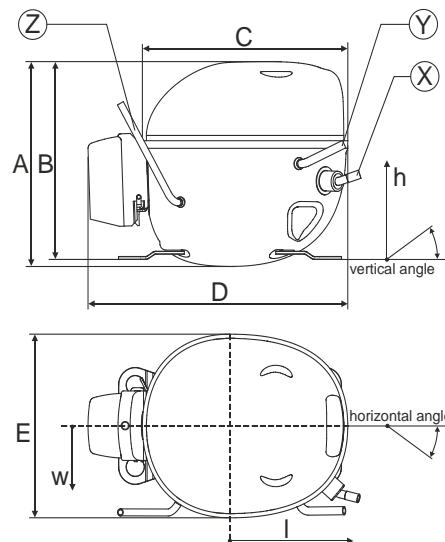

## Compressor fixation

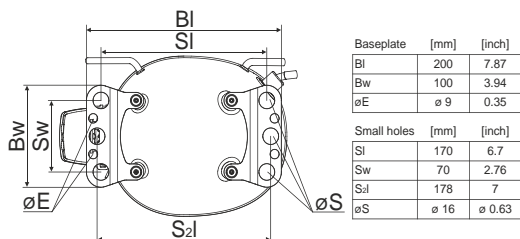

### Bolt joint

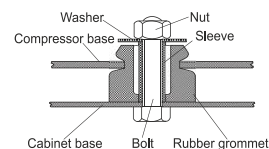

### Snap-on

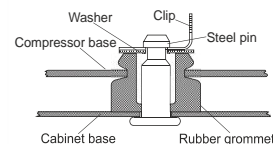

## Mounting accessories

	one comp.	multi pack
Bolt joint   M6   ø16mm	118-1917	118-1918
Bolt joint   ø1/4"   ø16mm	118-1946	
Snap-on   ø7,3   ø16mm	118-1947	118-1919

## Model

Designation	<b>DLE7.5CN</b>	<b>220-240V/50Hz</b>	<b>Conf. 1</b>	Sales code:	<b>102H4827</b>
-------------	-----------------	----------------------	----------------	-------------	-----------------

## Configuration

Motorconfiguration	RSIR
Power supply (nominal)	220-240V/50Hz 1~
Refrigerant	R290
Application	LBP+MBP
Voltage range	198-254V
Starting torque	LST
Approvals	VDE
	CCC

## Electrical accessories / wiring diagram

RSIR

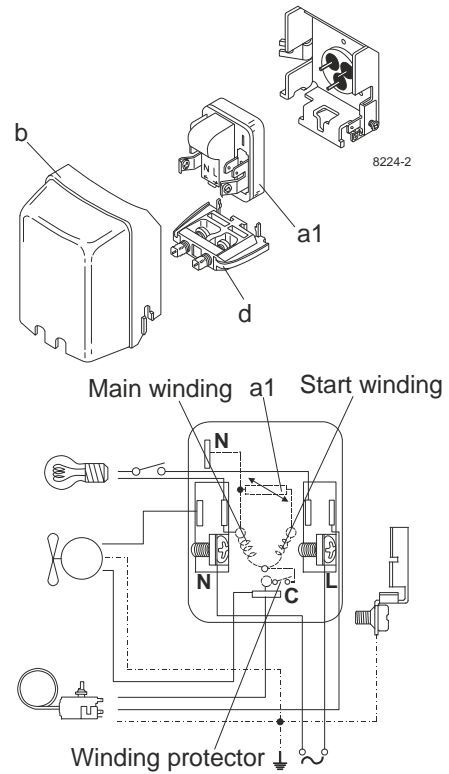

## Ambient temperatures / system cooling

Ambient temperature min.:	10°C / 50°F
Ambient temperature max.:	43°C / 110°F

System cooling (n/a: outside limits)			
T ambient	LBP	MBP	HBP
32°C / 90°F	fan 3m/s	fan 3m/s	n/a
38°C / 100°F	fan 3m/s	fan 3m/s	n/a
43°C / 110°F	fan 3m/s	fan 3m/s	n/a

## Operation pressure range

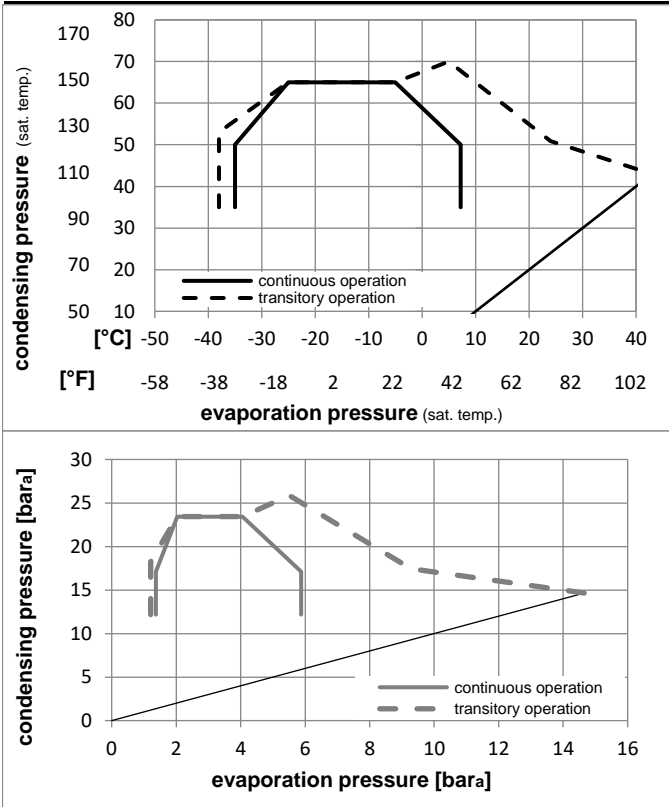

## Components (already pre-assembled)

a1	e-PTC starter (220V, 250hm, 4.8mm)	103N0050
b	plastic cover	103N0491
d	cord relief	103N1010

## Model

Designation **DLE7.5CN 220-240V/50Hz** Conf. 1 Sales code: **102H4827**

## Optimization + standard conditions

220-240V/50Hz 1~, RSIR, fan 3m/s, VDE, CCC

	Evaporating pressure (saturation temperature)				Condensing pressure (saturation temperature)						Power consumption			ASHRAE LBP
	pe	pc	RGT	Tliq	Cooling capacity			COP	EER	P1	I	Ref. mass flow m		
	[°C]	[°C]	[°C]	[°C]	[W]	[Btu/h]	[kcal/h]	[W/W]	[Btu/Wh]	[kcal/Wh]	[W]	[A]	[kg/h]	
	-23,3	54,4	32,2	32,2	365,4	1248	314,5	1,47	5,02	1,26	248,8	1,59	3,70	ASHRAE LBP
	[-10]	130	90	90										
	-25	55	32	55	274,9	939	236,6	1,14	3,90	0,98	240,7	1,56	3,42	cecomaf LBP
	[-13]	131	89,6	131										
	-35	40	20	40	208,9	713	179,7	1,17	3,99	1,01	178,8	1,40	2,39	EN12900 LBP
	[-31]	104	68	104										
	-6,66	54,4	35	46,1	643,7	2198	553,9	1,91	6,53	1,64	336,8	1,91	7,34	ASHRAE MBP
	[20]	130	95	115										
	-10	55	32	55	511,4	1746	440,1	1,59	5,44	1,37	320,9	1,85	6,47	cecomaf MBP
	[14]	131	89,6	131										
	-10	45	20	45	571,7	1953	492,0	1,99	6,78	1,71	287,8	1,73	7,02	EN12900 MBP
	[14]	113	68	113										

## Performance tables

220-240V/50Hz 1~, RSIR, fan 3m/s, VDE, CCC

	pe	Cooling capacity			COP	EER	P1	I	m		
	[°C]	[°F]	[W]	[Btu/h]	[kcal/h]	[W/W]	[Btu/Wh]	[kcal/Wh]	[W]	[A]	[kg/h]
[°C / °F]	-35	-31	202,4	691	174,2	1,10	3,74	0,94	184,7	1,41	2,27
cond. pressure	-25	-13	322,1	1100	277,2	1,43	4,88	1,23	225,5	1,52	3,63
pc= 45/113	-15	5	489,5	1672	421,3	1,83	6,26	1,58	266,9	1,65	5,57
return gas temp.	-10	14	595,2	2033	512,2	2,07	7,06	1,78	287,8	1,73	6,81
RGT= 32/90	-5	23	717,6	2451	617,6	2,32	7,93	2,00	309,0	1,81	8,26
liquid temp	0	32	858,5	2932	738,8	2,60	8,87	2,24	330,4	1,89	9,96
Tliq= 45/113	7,2	45	1097,0	3746	944,0	3,03	10,35	2,61	361,8	2,02	12,89
[°C / °F]	-35	-31	169,1	578	145,6	0,90	3,08	0,78	187,5	1,41	2,09
cond. pressure	-25	-13	274,9	939	236,6	1,14	3,90	0,98	240,7	1,56	3,42
pc= 55/131	-15	5	420,0	1434	361,5	1,43	4,88	1,23	294,1	1,75	5,28
return gas temp	-10	14	511,4	1746	440,1	1,59	5,44	1,37	320,9	1,85	6,47
RGT= 32/90	-5	23	617,5	2109	531,4	1,77	6,06	1,53	348,0	1,96	7,87
liquid temp	0	32	739,9	2527	636,8	1,97	6,73	1,70	375,2	2,07	9,50
Tliq= 55/131	7,2	45	948,3	3239	816,1	2,29	7,80	1,97	414,9	2,24	12,35