



Compressor
Voltage Code : FZ

AJ2446P-FZ

Low Temp. Commercial (BP)

220 - 240V 1~ 50 Hz

R452A / R404A / R455A / R454C

AJ2446P-FZ3A

Conditions	Frequency	Nominal Cooling Capacity		Sound Power ISO3745 / ISO 3743-1
		Watts	BTU/h	
CECOMAF / R452A	50 Hz	762	2599	57 dBA
CECOMAF / R404A	50 Hz	809	2760	57 dBA
CECOMAF / R455A	50 Hz	679	2314	57 dBA
CECOMAF / R454C	50 Hz	636	2169	57 dBA

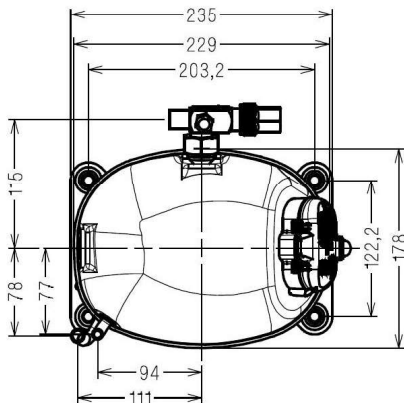
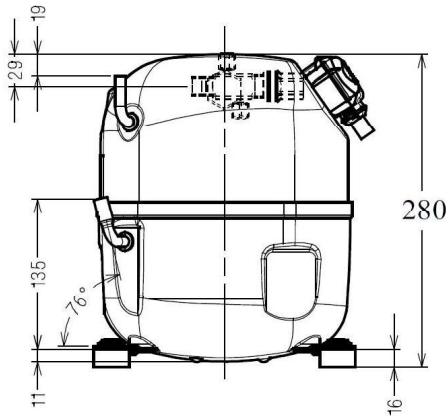

* CECOMAF : T°Cond. 55.0°C / T°Evap. -25.0°C / T°Return gas temp.. 32.0°C
T°Subcooling. 0.0K

Certificates :



Displacement (cc)	26,2
Net Weight (Kg)	21.5
Oil Quantity (cc)	475.0
Oil Type	Polyolester
Expansion Device	Capillary_Tube/Expansion_Valve
Cooling	Fan
Main Winding (Ohm)	2.9
Start Winding (Ohm)	8.8
Current	
RLA (A)	3,9
MCC (A)	8,2
LRA (A)	29,5
Electrical Equipment	CSR
Overload	MST18AIN
Time Check	7,5s - 14s / 20,7 A
Open Temp	120° C
Close Temp	69° C
Optional	T0750
Start Capacitor	88 µF / 330 V
Run Capacitor	15 µF / 400 V
Potential Relay	RVA40**
Pick Up	280/310V
Drop Out	60/121V
Refrigerating connection for	
Suction Tube	15.9 (5/8")
Discharge Tube	7.9 (5/16")
Process Tube	6.35 (1/4")

Note : Tecumseh reserves the right to change information contained in this document without notification.



Tecumseh

AJ2446P-FZ	Tension FZ : 220 - 240V 1~ 50 Hz
-------------------	---

Les performances sont données dans les conditions CECOMAF :	Gaz aspirés :	32.0 °C
Condition Dew	Sous refroidissement :	0.0 K
The performance data are in CECOMAF conditions :	Return gas :	32.0 °C
Dew Condition	Subcooling :	0.0 K

50 Hz R452A									
N°3604									
4 T condensation	5 T évaporation	(°C)	-40	-35	-30	-25	-20	-15	-10
30	1 P frigorifique	(Watt)	545	767	1034	1354	1731	2173	2685
	2 P absorbée	(W)	481	561	641	721	803	886	971
	3 I absorbée	(A)	2.27	2.57	2.89	3.25	3.64	4.07	4.54
40	1 P frigorifique	(Watt)		607	842	1123	1455	1844	2297
	2 P absorbée	(W)		557	656	755	857	962	1070
	3 I absorbée	(A)		2.56	2.97	3.41	3.88	4.38	4.92
50	1 P frigorifique	(Watt)			645	882	1164	1496	1885
	2 P absorbée	(W)			652	771	894	1020	1151
	3 I absorbée	(A)			3.02	3.53	4.08	4.66	5.27
60	1 P frigorifique	(Watt)				645	871	1142	1463
	2 P absorbée	(W)				772	915	1063	1216
	3 I absorbée	(A)				3.63	4.25	4.90	5.58

50 Hz R404A									
N°3605									
4 T condensation	5 T évaporation	(°C)	-40	-35	-30	-25	-20	-15	-10
30	1 P frigorifique	(Watt)	599	836	1119	1452	1841	2291	2806
	2 P absorbée	(W)	516	602	688	772	856	939	1022
	3 I absorbée	(A)	2.44	2.76	3.10	3.48	3.89	4.32	4.78
40	1 P frigorifique	(Watt)		662	908	1197	1535	1925	2373
	2 P absorbée	(W)		604	707	810	915	1020	1128
	3 I absorbée	(A)		2.77	3.20	3.65	4.13	4.64	5.18
50	1 P frigorifique	(Watt)			696	938	1221	1550	1929
	2 P absorbée	(W)			708	831	956	1085	1217
	3 I absorbée	(A)			3.28	3.81	4.36	4.95	5.56
60	1 P frigorifique	(Watt)				682	908	1173	1480
	2 P absorbée	(W)				837	984	1135	1292
	3 I absorbée	(A)				3.94	4.58	5.24	5.93

1 = cooling capacity 2 = power input 3 = current 4 = condensing temperature 5 = evaporating temperature

Nota : Tecumseh se réserve le droit de modifier les informations contenues dans ce document sans préavis.

Note : Tecumseh reserves the right to change information contained in this document without notification.

© 2024 Tecumseh Products Company
All rights reserved



Tecumseh

AJ2446P-FZ	Tension FZ : 220 - 240V 1~ 50 Hz
-------------------	---

Les performances sont données dans les conditions CECOMAF :	Gaz aspirés :	32.0 °C
Condition Dew	Sous refroidissement :	0.0 K
The performance data are in CECOMAF conditions :	Return gas :	32.0 °C
Dew Condition	Subcooling :	0.0 K

50 Hz R455A									
N°3318									
4 T condensation	5 T évaporation	(°C)	-40	-35	-30	-25	-20	-15	-10
30	1 P frigorifique	(Watt)	386	593	835	1117	1445	1824	2260
	2 P absorbée	(W)	399	485	566	641	710	773	830
	3 I absorbée	(A)	2.06	2.40	2.74	3.09	3.44	3.79	4.14
40	1 P frigorifique	(Watt)	272	470	696	957	1257	1603	2001
	2 P absorbée	(W)	375	478	578	675	768	857	942
	3 I absorbée	(A)	1.95	2.38	2.82	3.25	3.69	4.14	4.59
50	1 P frigorifique	(Watt)		336	541	774	1040	1347	1699
	2 P absorbée	(W)		453	571	688	804	918	1030
	3 I absorbée	(A)		2.27	2.79	3.32	3.86	4.39	4.93
60	1 P frigorifique	(Watt)			385	584	810	1070	1370
	2 P absorbée	(W)			545	682	819	957	1095
	3 I absorbée	(A)			2.68	3.30	3.92	4.55	5.19

50 Hz R454C									
N°3317									
4 T condensation	5 T évaporation	(°C)	-40	-35	-30	-25	-20	-15	-10
30	1 P frigorifique	(Watt)	365	561	795	1071	1395	1772	2207
	2 P absorbée	(W)	383	460	535	606	674	739	800
	3 I absorbée	(A)	1.98	2.29	2.60	2.92	3.24	3.56	3.88
40	1 P frigorifique	(Watt)	262	445	660	912	1206	1548	1941
	2 P absorbée	(W)	363	454	545	634	723	810	895
	3 I absorbée	(A)	1.88	2.28	2.68	3.08	3.49	3.90	4.31
50	1 P frigorifique	(Watt)		319	510	731	988	1287	1633
	2 P absorbée	(W)		431	536	641	748	856	965
	3 I absorbée	(A)		2.16	2.65	3.14	3.63	4.12	4.62
60	1 P frigorifique	(Watt)			356	541	756	1006	1297
	2 P absorbée	(W)			509	630	754	881	1011
	3 I absorbée	(A)			2.49	3.07	3.65	4.23	4.82

1 = cooling capacity 2 = power input 3 = current 4 = condensing temperature 5 = evaporating temperature

Nota : Tecumseh se réserve le droit de modifier les informations contenues dans ce document sans préavis.

Note : Tecumseh reserves the right to change information contained in this document without notification.

© 2024 Tecumseh Products Company
All rights reserved