

Condensing unit  
Voltage Code : TZ

# TAJN4511YHR-TZ

High Temp. Commercial (HP)

400V 3~ 50Hz / 440V 3~ 60 Hz

R134a / R513A

TAJN4511YHR-TZ

Conditions	Frequency	Nominal Cooling Capacity		Sound Power ISO3745 / ISO 3743-1
		Watts	BTU/h	
EN13215 / R134a	50 Hz / 60 Hz	1481 / 1665	5050 / 5679	64 dBA
EN13215 / R513A	50 Hz	1590	5421	64 dBA

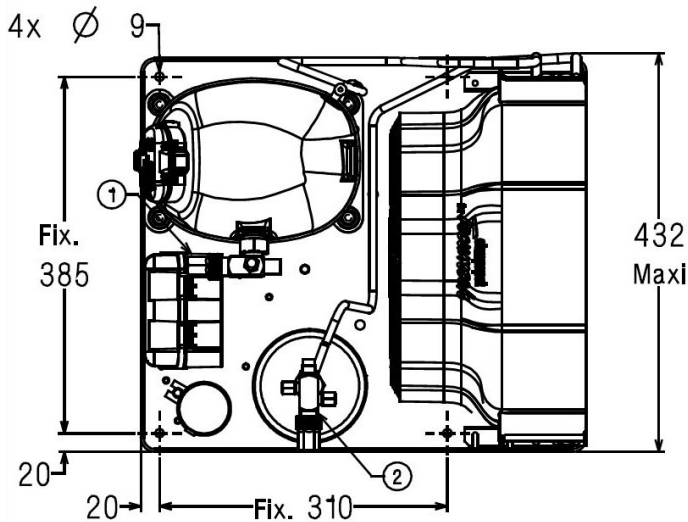
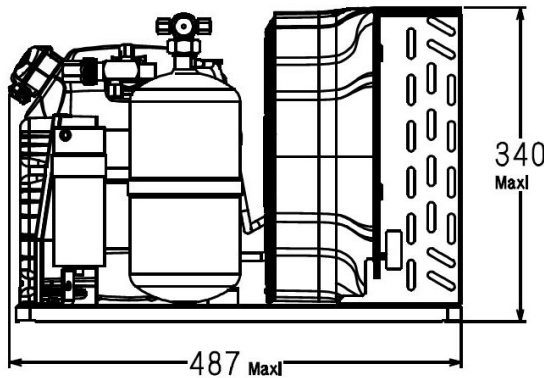

\* EN13215 : T°Ambient 32.0°C / T°Evap. -10.0°C / T°Return gas temp.. 20.0°C  
T°Subcooling. 3.0K

<b>Net Weight (Kg)</b>	33.0
<b>Expansion device</b>	Expansion_Valve
<b>Air Flow (m³/h)</b>	900 / 900
<b>Compo Data Sheet</b>	214QU-TZ
<b>Elec Comp Type</b>	TRI
<b>Current (Amp)</b>	
Load Rated Amp	2.6   2.6
Max Cont Current	3.5   3.5
Lock Rotor Amp	16.9   17.5
<b>Fan</b>	
Speed (rpm)	1200 / 1200
Power (W)	30.0
Diameter (mm)	300
Protection	Overload
IP Level	IP54
<b>Condenser</b>	300/3900
<b>Liquid Receiver</b>	
Capacity (L)	2.35
Maximum Pressure (Bars)	32.0
<b>Suction Line</b>	
Suction Type	Vanne Orientable
For Tubing Out Diam	15.9 (5/8")
Suction Connection Type	Brased
<b>Liquid Line</b>	
Liquid Line Type	Vanne Orientable
For Tubing Out Diam	9.5 (3/8")
Liquid Connecton Type	Brased
<b>Connection Type</b>	VR
<b>Fan Guard</b>	maille < à 8mm

Note : Tecumseh reserves the right to change information contained in this document without notification.



**Tecumseh**

<b>TAJN4511YHR-TZ</b>	<b>Tension TZ : 400V 3~ 50Hz / 440V 3~ 60 Hz</b>
-----------------------	--

Les performances sont données dans les <b>conditions EN13215</b> :	Gaz aspirés :	20.0 °C
Condition Dew	Sous refroidissement :	3.0 K
The performance data are in <b>EN13215 conditions</b> :	Return gas :	20.0 °C
Dew Condition	Subcooling :	3.0 K

<b>50 Hz R134a</b>											
<b>N°5059</b>											
5   T ambience	6   T évaporation	(°C)	-25	-20	-15	-10	-5	0	5	10	15
<b>25</b>	1   P frigorifique	(Watt)	755	1019	1314	1639	1988	2356	2736	3120	3496
	2   P absorbée	(W)	517	599	686	781	886	1004	1137	1289	1463
	3   I absorbée	(A)	1.56	1.64	1.73	1.85	1.99	2.15	2.33	2.54	2.78
	4   Tc	(°C)	32.1	34.7	37.4	40.4	43.6	47.0	50.6	54.5	58.5
<b>32</b>	1   P frigorifique	(Watt)		903	1181	1481	1800	2132	2470	2806	
	2   P absorbée	(W)		608	704	808	921	1048	1191	1352	
	3   I absorbée	(A)		1.63	1.74	1.88	2.03	2.20	2.40	2.62	
	4   Tc	(°C)		40.4	43.1	46.0	49.1	52.4	56.0	59.7	
<b>43</b>	1   P frigorifique	(Watt)			972	1234	1505	1780			
	2   P absorbée	(W)			720	839	968	1111			
	3   I absorbée	(A)			1.76	1.91	2.09	2.28			
	4   Tc	(°C)			52.0	54.8	57.8	60.9			

<b>60 Hz R134a</b>											
<b>N°5059</b>											
5   T ambience	6   T évaporation	(°C)	-25	-20	-15	-10	-5	0	5	10	15
<b>25</b>	1   P frigorifique	(Watt)	820	1133	1478	1852	2247	2655	3070	3483	3886
	2   P absorbée	(W)	565	690	817	951	1094	1251	1424	1617	1833
	3   I absorbée	(A)	1.48	1.58	1.71	1.86	2.04	2.24	2.47	2.72	3.01
	4   Tc	(°C)	32.0	35.2	38.4	41.8	45.2	48.7	52.2	55.9	59.6
<b>32</b>	1   P frigorifique	(Watt)		986	1316	1665	2028	2397	2764	3121	
	2   P absorbée	(W)		680	823	971	1130	1301	1490	1698	
	3   I absorbée	(A)		1.57	1.72	1.88	2.07	2.29	2.53	2.80	
	4   Tc	(°C)		40.7	44.0	47.4	50.9	54.4	58.1	61.8	
<b>43</b>	1   P frigorifique	(Watt)			1039	1354	1670				
	2   P absorbée	(W)			802	979	1165				
	3   I absorbée	(A)			1.71	1.90	2.11				
	4   Tc	(°C)			52.8	56.3	59.9				

1 = cooling capacity 2 = power input 3 = current 4 = condensing temperature 5 = ambient temperature 6 = evaporating temperature

Nota : Tecumseh se réserve le droit de modifier les informations contenues dans ce document sans préavis.

Note : Tecumseh reserves the right to change information contained in this document without notification.

© 2021 Tecumseh Products Company  
All rights reserved



**Tecumseh**

<b>TAJN4511YHR-TZ</b>	<b>Tension TZ : 400V 3~ 50Hz / 440V 3~ 60 Hz</b>
-----------------------	--

Les performances sont données dans les <b>conditions EN13215</b> :	Gaz aspirés :	20.0 °C
Condition Dew	Sous refroidissement :	3.0 K
The performance data are in <b>EN13215 conditions</b> :	Return gas :	20.0 °C
Dew Condition	Subcooling :	3.0 K

<b>50 Hz R513A</b>											
											
										<b>N°6462</b>	
5   T ambience	6   T évaporation	(°C)	-25	-20	-15	-10	-5	0	5	10	15
<b>25</b>	1   P frigorifique	(Watt)	886	1158	1454	1771	2103	2443	2784	3115	3425
	2   P absorbée	(W)	564	648	736	834	942	1065	1206	1369	1557
	3   I absorbée	(A)	1.56	1.64	1.73	1.85	1.99	2.15	2.33	2.54	2.78
	4   Tc	(°C)	32.1	34.7	37.4	40.4	43.6	47.0	50.6	54.4	58.5
<b>32</b>	1   P frigorifique	(Watt)	760	1020	1298	1590	1890	2194	2492	2776	
	2   P absorbée	(W)	559	652	751	858	976	1110	1262	1436	
	3   I absorbée	(A)	1.54	1.63	1.74	1.88	2.03	2.20	2.40	2.62	
	4   Tc	(°C)	37.9	40.4	43.1	46.0	49.1	52.4	56.0	59.7	
<b>43</b>	1   P frigorifique	(Watt)			1055	1309	1561	1808			
	2   P absorbée	(W)			759	885	1022	1174			
	3   I absorbée	(A)			1.76	1.91	2.09	2.28			
	4   Tc	(°C)			52.0	54.8	57.7	60.9			

© 2021 Tecumseh Products Company  
All rights reserved

1 = cooling capacity 2 = power input 3 = current 4 = condensing temperature 5 = ambient temperature 6 = evaporating temperature

**Nota : Tecumseh se réserve le droit de modifier les informations contenues dans ce document sans préavis.**

**Note : Tecumseh reserves the right to change information contained in this document without notification.**