

Compresseur / Compressor
Code tension / Voltage code : F

CAJ4492Y

Froid commercial et industriel positif (HP)
Commercial & industrial application (HBP)

220-240V / 50Hz - 1~

R134a



N° 214LS-F - ind e

Conditions Conditions	fréquence frequency	Prod frigorifique nominale / nominal refrigerating capacity			Puis. sonore Sound level
		Watts	Kcal/h	BTU/h	
EN 12900	50 Hz	2108	1813	7188	ISO 3745 / ISO 3743-1 59 dBA
Cecomaf	50 Hz	2026			

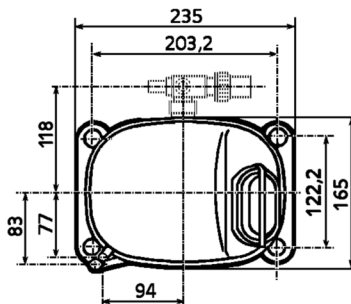
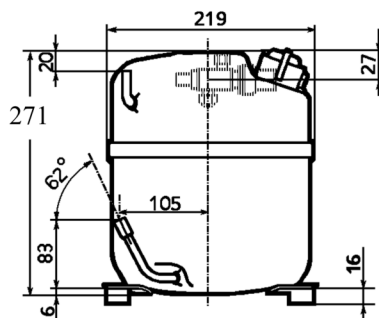

Cylindrée / Displacement : 25.95 cm³
Poids net / Net weight : 22 Kg
Charge en huile / Oil charge : 887 cm³
Type d'huile / Oil type : P.O.E /
Détente / Expansion device : Capillaire/Détendeur
 Capillary/Exp° valve

Refroidissement / Cooling : Ventilé / Forced

Résistance à 20° C / Windings resistances at 20° C

Phase princ. / Main Winding : 2.1 Ohms
 aux. / Auxiliary Winding : 14.1 Ohms

Intensité / Current

nom. / Rated current RLA : 5.6 A
 max. / Max current : 8.4 A
 dém. / Start current LRA : 27.5 A

Ap. Electrique / Electrical equipment : CSIR

Protecteur / Overload :

MST18AIN
 Temporisation / Time Check : 7.5s - 14s / 20.7 A
 T° ouverture / Opening temp.: 120° C
 fermeture / Closing temp.: 69° C
 Option / optional : T0750

Relais Intensité / Current relay :

MTRPH0033
 enclenchement / Pick up : 15,2A
 déclenchement / Drop out : 12,9A
 Option / optional : 3ARR18A98B

Condensateur dém. / Start capacitor : 64 µF / 330 V

Pour conduites Ø ext / For tubing O.D.

Aspiration Suction	Refoulement Discharge	Charge Process
12.7 (1/2")	7.9 (5/16")	6.35 (1/4")

Les caractéristiques données dans cette fiche technique peuvent évoluer sans avis préalable, avec les améliorations que 'TECUMSEH EUROPE' entend toujours apporter à sa production.
 'TECUMSEH EUROPE', in a constant endeavour to improve its products reserves the right to change any information contained in this leaflet without prior warning.



CAJ4492Y	Tension F : 220 - 240V 1~ 50 Hz	R134a	N°214LS-F	Ind e
-----------------	--	--------------	------------------	--------------

Les performances sont données dans les conditions EN 12900 : Elles sont certifiées uniquement en 50 Hz	Gaz aspirés : 20°C Sous refroidissement : 0°K
The performance data are in EN 12900 conditions : They are only certified in 50 Hz	Return gas : 20°C Subcooling : 0°K

50 Hz R134a											
4 T condensation	5 T évaporation	(°C)	-25	-20	-15	-10	-5	0	5	10	15
30	1 P frigorifique	(W)	592	828	1113	1455	1864	2348	2915	3574	4334
	2 P absorbée	(W)	415	479	536	588	636	680	723	764	804
	3 I absorbée	(A)	4.32	4.39	4.47	4.58	4.7	4.85	5.01	5.2	5.4
40	1 P frigorifique	(W)		664	925	1230	1590	2013	2507	3081	3744
	2 P absorbée	(W)		483	562	634	701	763	823	880	935
	3 I absorbée	(A)		4.37	4.53	4.71	4.91	5.13	5.37	5.62	5.9
50	1 P frigorifique	(W)			722	996	1313	1681	2108	2603	3174
	2 P absorbée	(W)			560	657	748	834	915	993	1068
	3 I absorbée	(A)			4.55	4.81	5.08	5.37	5.69	6.02	6.37
60	1 P frigorifique	(W)				748	1028	1346	1711	2133	2619
	2 P absorbée	(W)				652	772	886	994	1098	1198
	3 I absorbée	(A)				4.87	5.22	5.59	5.97	6.38	6.81
1 = refrigerating capacity 2 = watt input 3 = current 4 = condensing temperature 5 = evaporating temperature											

Nota : Les caractéristiques données dans cette fiche technique peuvent évoluer sans avis préalable, avec les améliorations que "TECUMSEH EUROPE" entend toujours apporter à sa production.

Note : "TECUMSEH EUROPE", in a constant endeavour to improve its products reserves the right to change any information contained in this leaflet without prior warning.