

EMC3117U



ENGINEERING CODE
513301849



REFRIGERANT
R-290



POWER SUPPLY
220-240 V 50 Hz



APPLICATION
L/MBP



MOTOR TYPE
RSCR



STANDARD
EN12900



COOLING CAPACITY
304 W



EFFICIENCY
2.16 W/W



DATA

GENERAL DATA

Model	EMC3117U
Type	Hermetic Reciprocating
Technology	ON/OFF
Compressor Application	L/MBP
Expansion Device	Capillary Tube
Compressor Cooling	Static/220
HP	1/4
Starting Torque	LST
Plant	BRAZIL

ELECTRICAL DATA

Start Winding Resistance	14.75 Ω at 25°C
Run Winding Resistance	19.97 Ω at 25°C
Locked Rotor Amperage (LRA) 50Hz	4.8 A

MECHANICAL DATA

Displacement	3.97 cm ³
Oil Charge	150 ml
Oil Type	ALQUILB
Oil Viscosity	ISO22
Weight	8.2 Kg

ELECTRICAL COMPONENTS

Run Capacitor	5.0 µf/350 V
CSR CSIR BOX	No
Starting Device Type	PTC
Starting Device Description	MI2021 V230
Overload Protection	AE13FHY8

PERFORMANCE

TESTED CONDITIONS

Tested Refrigerant	R-290
Tested Application	MBP
Tested Standard	EN12900
Tested Cooling	Static
Tested Voltage	220 V
Max Refrigerant Charge	150 g
Refrigerant Temperature	Dew

RATED POINTS

Condensing Temperature °C	Evaporating Temperature °C	Cooling Capacity W	Efficiency W/W	Power Consumption W	Current A	Gas Flow Rate kg/h
45	-10	304	2.16	141	-	3.74

Test Condition: Subcooling 0 K, Return Gas 20 °C. Data are an indication of performance based simulation.

PERFORMANCE CURVE
Condensing Temperature 35°C

Evaporating Temperature °C	Cooling Capacity W	Efficiency W/W	Power Consumption W	Current A	Gas Flow Rate kg/h
-35	120	1.59	76	-	1.32
-30	151	1.78	85	-	1.66
-25	189	1.99	95	-	2.08
-20	234	2.23	105	-	2.60
-15	288	2.49	115	-	3.20
-10	350	2.79	125	-	3.91
-5	420	3.14	134	-	4.73
0	499	3.54	141	-	5.67

Test Condition: Subcooling 0 K, Return Gas 20 °C. Data are an indication of performance based simulation.

PERFORMANCE CURVE
Condensing Temperature 45°C

Evaporating Temperature °C	Cooling Capacity W	Efficiency W/W	Power Consumption W	Current A	Gas Flow Rate kg/h
-35	105	1.32	80	-	1.27
-30	131	1.46	90	-	1.58
-25	164	1.62	101	-	1.98
-20	203	1.78	114	-	2.47
-15	250	1.96	127	-	3.06
-10	304	2.16	141	-	3.74
-5	366	2.38	153	-	4.53
0	435	2.63	165	-	5.44

Test Condition: Subcooling 0 K, Return Gas 20 °C. Data are an indication of performance based simulation.

PERFORMANCE CURVE
Condensing Temperature 55°C

Evaporating Temperature °C	Cooling Capacity W	Efficiency W/W	Power Consumption W	Current A	Gas Flow Rate kg/h
-25	138	1.34	103	-	1.86
-20	171	1.46	118	-	2.32
-15	211	1.58	133	-	2.88
-10	257	1.72	150	-	3.53
-5	310	1.86	166	-	4.29
0	370	2.03	183	-	5.17

Test Condition: Subcooling 0 K, Return Gas 20 °C. Data are an indication of performance based simulation.

ENVELOPE

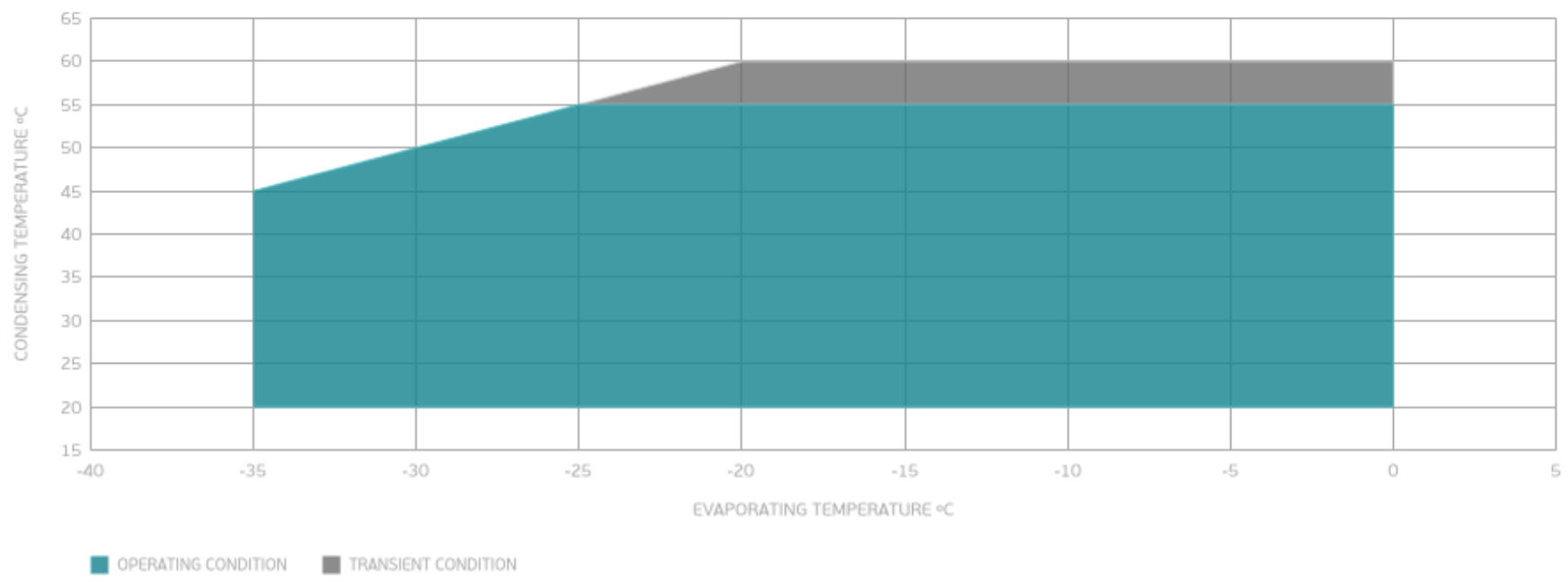

External

EXTERNAL CHARACTERISTICS

Base Plate SMALL

Tray Holder NO

Connector	Internal Diameter	Shape	Material
Suction	6.1 mm	SLANTED 42° UP + 45° TO BACK	COPPER
Discharge	4.94 mm	SLANTED 0° UP + 45° TO BACK	COPPER
Process	6.1 mm	SLANTED 45° UP + 45° TO BACK	COPPER

EXTERNAL DIMENSIONS

SHELL

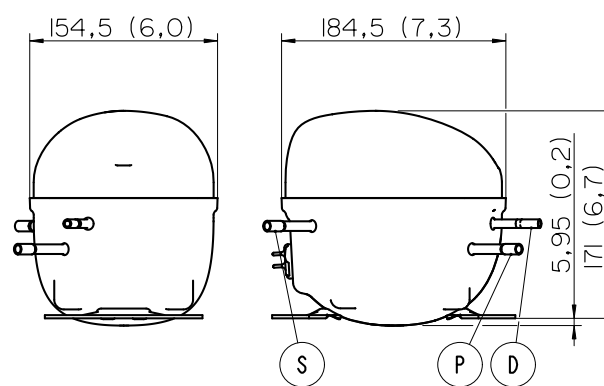

BASE



FENCE

