

EMC3117U



ENGINEERING CODE
513301849



REFRIGERANT
R-290



POWER SUPPLY
220-240 V 50 Hz



APPLICATION
L/MBP



MOTOR TYPE
RSCR



STANDARD
EN12900



COOLING CAPACITY
115 W



EFFICIENCY
1.49 W/W



DATA

GENERAL DATA

Model	EMC3117U
Type	Hermetic Reciprocating
Technology	ON/OFF
Compressor Application	L/MBP
Expansion Device	Capillary Tube
Compressor Cooling	Fan/220
HP	1/4
Starting Torque	LST
Plant	BRAZIL

ELECTRICAL DATA

Start Winding Resistance	14.75 Ω at 25°C
Run Winding Resistance	19.97 Ω at 25°C
Locked Rotor Amperage (LRA) 50Hz	4.8 A

MECHANICAL DATA

Displacement	3.97 cm ³
Oil Charge	150 ml
Oil Type	ALQUILB
Oil Viscosity	ISO22
Weight	8.2 Kg

ELECTRICAL COMPONENTS

Run Capacitor	5.0 µf/350 V
CSR CSIR BOX	No
Starting Device Type	PTC
Starting Device Description	MI2021 V230
Overload Protection	AE13FHY8

PERFORMANCE

TESTED CONDITIONS

Tested Refrigerant	R-290
Tested Application	LBP
Tested Standard	EN12900
Tested Cooling	Fan
Tested Voltage	220 V
Max Refrigerant Charge	150 g
Refrigerant Temperature	Dew

RATED POINTS

Condensing Temperature °C	Evaporating Temperature °C	Cooling Capacity W	Efficiency W/W	Power Consumption W	Current A	Gas Flow Rate kg/h
40	-35	115	1.49	78	-	1.32

Test Condition: Subcooling 0 K, Return Gas 20 °C. Data are an indication of performance based simulation.

PERFORMANCE CURVE
Condensing Temperature 35°C

Evaporating Temperature °C	Cooling Capacity W	Efficiency W/W	Power Consumption W	Current A	Gas Flow Rate kg/h
-35	124	1.64	76	-	1.36
-30	157	1.86	84	-	1.73
-25	197	2.12	93	-	2.17
-20	244	2.41	101	-	2.71
-15	299	2.74	109	-	3.33
-10	363	3.12	116	-	4.06
-5	435	3.58	122	-	4.90
0	515	4.12	125	-	5.85

Test Condition: Subcooling 0 K, Return Gas 20 °C. Data are an indication of performance based simulation.

PERFORMANCE CURVE
Condensing Temperature 45°C

Evaporating Temperature °C	Cooling Capacity W	Efficiency W/W	Power Consumption W	Current A	Gas Flow Rate kg/h
-35	107	1.36	79	-	1.29
-30	135	1.52	89	-	1.63
-25	170	1.70	100	-	2.06
-20	211	1.90	111	-	2.57
-15	260	2.13	122	-	3.18
-10	316	2.39	132	-	3.89
-5	380	2.68	142	-	4.71
0	453	3.03	150	-	5.66

Test Condition: Subcooling 0 K, Return Gas 20 °C. Data are an indication of performance based simulation.

PERFORMANCE CURVE
Condensing Temperature 55°C

Evaporating Temperature °C	Cooling Capacity W	Efficiency W/W	Power Consumption W	Current A	Gas Flow Rate kg/h
-25	144	1.40	103	-	1.94
-20	179	1.54	116	-	2.43
-15	221	1.70	130	-	3.01
-10	269	1.88	143	-	3.70
-5	325	2.08	156	-	4.50
0	389	2.31	169	-	5.43

Test Condition: Subcooling 0 K, Return Gas 20 °C. Data are an indication of performance based simulation.

ENVELOPE

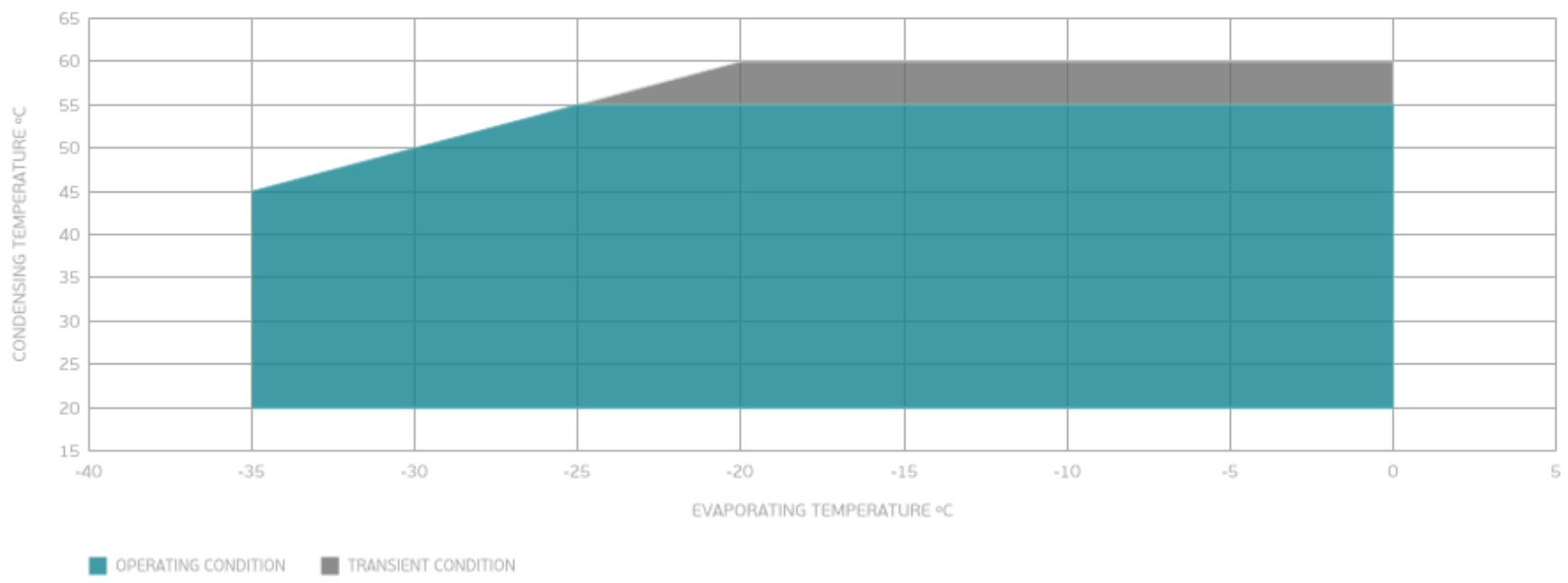

External

EXTERNAL CHARACTERISTICS

Base Plate SMALL

Tray Holder NO

Connector	Internal Diameter	Shape	Material
Suction	6.1 mm	SLANTED 42° UP + 45° TO BACK	COPPER
Discharge	4.94 mm	SLANTED 0° UP + 45° TO BACK	COPPER
Process	6.1 mm	SLANTED 45° UP + 45° TO BACK	COPPER

EXTERNAL DIMENSIONS

SHELL

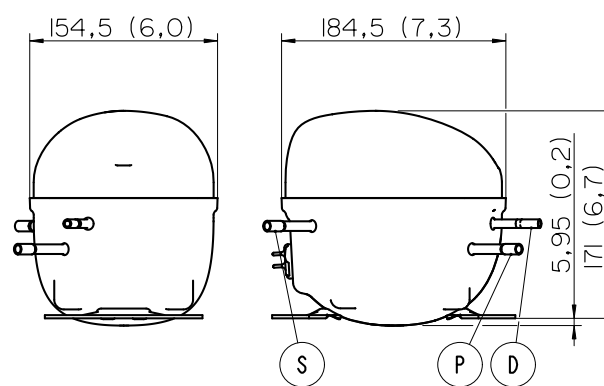

BASE



FENCE

