

EMC3130U



**ENGINEERING CODE**  
513301832

**REFRIGERANT**  
R-290

**POWER SUPPLY**  
220-240 V 50 Hz

**APPLICATION**  
L/MBP

**MOTOR TYPE**  
RSCR

**STANDARD**  
EN12900

**COOLING CAPACITY**  
197 W

**EFFICIENCY**  
1.5 W/W



DATA

GENERAL DATA

Model	EMC3130U
Type	Hermetic Reciprocating
Technology	ON/OFF
Compressor Application	L/MBP
Expansion Device	Capillary Tube
Compressor Cooling	Fan/220
HP	1/3
Starting Torque	LST
Plant	BRAZIL

ELECTRICAL DATA

Start Winding Resistance	13.5 Ω at 25°C
Run Winding Resistance	13.7 Ω at 25°C
Locked Rotor Amperage (LRA) 50Hz	6.6 A
Rated Load Amperage (LMBP) at 50 Hz	0.7 A
Rated Load Amperage (HBP) at 50 Hz	0.8 A

## MECHANICAL DATA

Displacement	6.92 cm <sup>3</sup>
Oil Charge	150 ml
Oil Type	ALQUILB
Oil Viscosity	ISO22
Weight	8.2 Kg

## ELECTRICAL COMPONENTS

Run Capacitor	8.0 µf/420 V
CSR CSIR BOX	No
Starting Device Type	PTC
Starting Device Description	V230
Overload Protection	AE15BU

## PERFORMANCE

### TESTED CONDITIONS

Tested Refrigerant	R-290
Tested Application	LBP
Tested Standard	EN12900
Tested Cooling	Fan
Tested Voltage	220 V
Max Refrigerant Charge	150 g
Refrigerant Temperature	Dew

### RATED POINTS

Condensing Temperature °C	Evaporating Temperature °C	Cooling Capacity W	Efficiency W/W	Power Consumption W	Current A	Gas Flow Rate kg/h
40	-35	197	1.5	132	0.63	2.26

Test Condition: Subcooling 0 K, Return Gas 20 °C. Data generated in accordance to EN 12900:2013 polynomial equation and tolerance guidelines.

**PERFORMANCE CURVE**
**Condensing Temperature 35°C**

Evaporating Temperature °C	Cooling Capacity W	Efficiency W/W	Power Consumption W	Current A	Gas Flow Rate kg/h
-35	210	1.65	127	0.61	2.30
-30	264	1.88	140	0.68	2.91
-25	333	2.14	155	0.74	3.68
-20	416	2.44	170	0.80	4.61
-15	513	2.77	185	0.86	5.71
-10	624	3.15	198	0.91	6.99
-5	751	3.60	208	0.97	8.46
0	893	4.15	215	1.02	10.14

Test Condition: Subcooling 0 K, Return Gas 20 °C. Data generated in accordance to EN 12900:2013 polynomial equation and tolerance guidelines.

**PERFORMANCE CURVE**
**Condensing Temperature 45°C**

Evaporating Temperature °C	Cooling Capacity W	Efficiency W/W	Power Consumption W	Current A	Gas Flow Rate kg/h
-35	183	1.35	135	0.65	2.20
-30	231	1.53	151	0.73	2.79
-25	291	1.73	168	0.80	3.53
-20	363	1.94	187	0.87	4.42
-15	448	2.17	206	0.94	5.48
-10	545	2.43	224	1.02	6.71
-5	655	2.71	241	1.09	8.12
0	779	3.04	256	1.17	9.73

Test Condition: Subcooling 0 K, Return Gas 20 °C. Data generated in accordance to EN 12900:2013 polynomial equation and tolerance guidelines.

**PERFORMANCE CURVE**
**Condensing Temperature 55°C**

Evaporating Temperature °C	Cooling Capacity W	Efficiency W/W	Power Consumption W	Current A	Gas Flow Rate kg/h
-25	244	1.40	174	0.84	3.30
-20	306	1.56	196	0.93	4.15
-15	379	1.73	219	1.02	5.17
-10	462	1.90	243	1.11	6.34
-5	556	2.09	266	1.21	7.70
0	661	2.30	287	1.31	9.24

Test Condition: Subcooling 0 K, Return Gas 20 °C. Data generated in accordance to EN 12900:2013 polynomial equation and tolerance guidelines.

## ENVELOPE

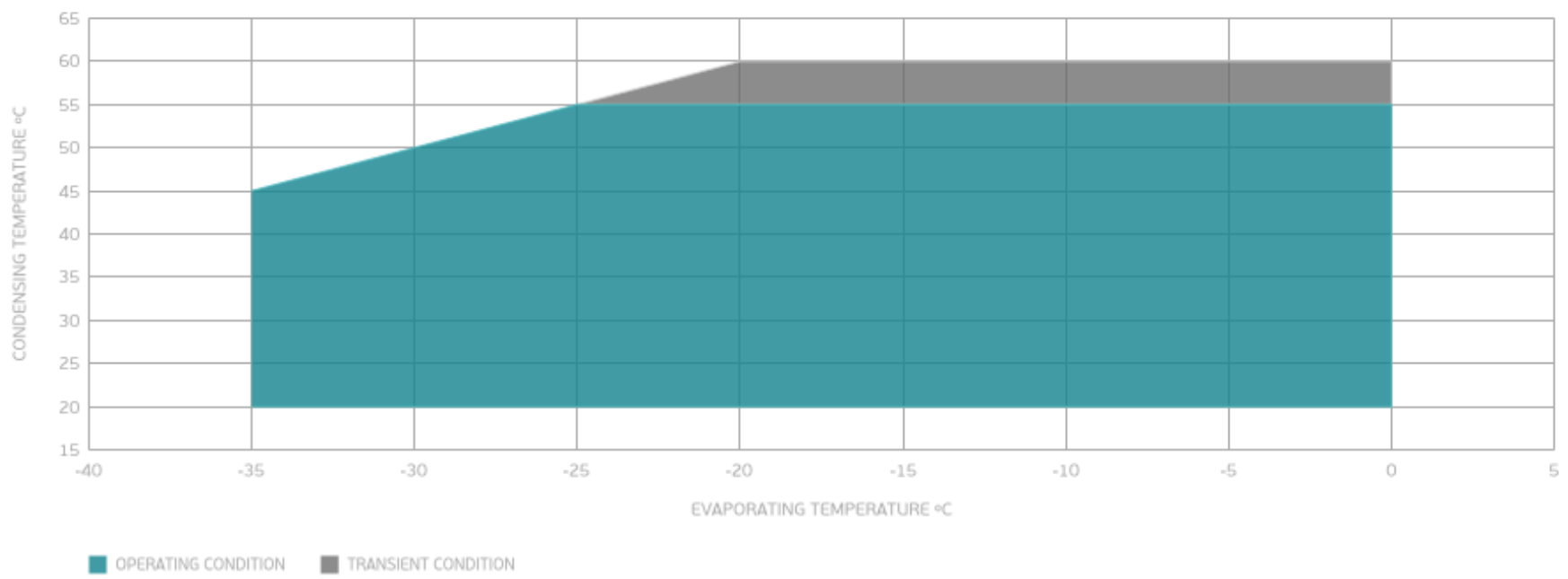

## External

### EXTERNAL CHARACTERISTICS

Base Plate SMALL

Tray Holder NO

Connector	Internal Diameter	Shape	Material
Suction	6.1 mm	SLANTED 42° UP + 45° TO BACK	COPPER
Discharge	4.94 mm	SLANTED 0° UP + 45° TO BACK	COPPER
Process	6.1 mm	SLANTED 45° UP + 45° TO BACK	COPPER

### EXTERNAL DIMENSIONS

#### SHELL

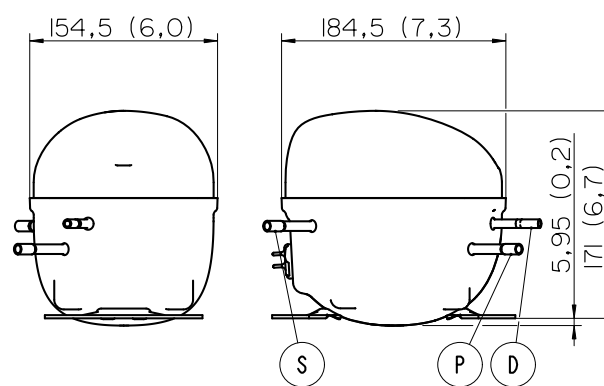

#### BASE



#### FENCE

