

NEK6165GK



**ENGINEERING CODE**  
957IA51



**REFRIGERANT**  
R-404A



**POWER SUPPLY**  
220-240 V 50 Hz



**APPLICATION**  
MBP



**MOTOR TYPE**  
CSIR



**STANDARD**  
EN12900



**COOLING CAPACITY**  
531 W



**EFFICIENCY**  
1.61 W/W



DATA

GENERAL DATA

Model	NEK6165GK
Type	Hermetic Reciprocating
Technology	ON/OFF
Compressor Application	MBP
Expansion Device	Capillary Tube or Expansion Valve
Compressor Cooling	Fan/220
HP	1/3
Starting Torque	HST
Plant	SLOVAKIA

ELECTRICAL DATA

Start Winding Resistance	28.9 Ω at 25°C
Run Winding Resistance	6.8 Ω at 25°C

## MECHANICAL DATA

Displacement	6.2 cm <sup>3</sup>
Oil Charge	350 ml
Oil Type	ESTER
Oil Viscosity	ISO22
Weight	10.4 Kg

## ELECTRICAL COMPONENTS

Start Capacitor	43-53 µf/330 V
CSR CSIR BOX	No
Starting Device Type	RELAY
Starting Device Description	MTRP-38*
Overload Protection	T0660/G5

## PERFORMANCE

### TESTED CONDITIONS

Tested Refrigerant	R-404A
Tested Application	MBP
Tested Standard	EN12900
Tested Cooling	Fan
Tested Voltage	220 V
Refrigerant Temperature	Dew

### RATED POINTS

Condensing Temperature °C	Evaporating Temperature °C	Cooling Capacity W	Efficiency W/W	Power Consumption W	Current A	Gas Flow Rate kg/h
45	-10	531	1.61	329	-	15.95

Test Condition: Subcooling 0 K, Return Gas 20 °C. Data are an indication of performance based simulation.

### PERFORMANCE CURVE

Condensing Temperature 35°C

Evaporating Temperature °C	Cooling Capacity W	Efficiency W/W	Power Consumption W	Current A	Gas Flow Rate kg/h
-20	450	1.84	245	-	11.65
-15	533	1.99	268	-	13.97
-10	635	2.16	294	-	16.74
-5	757	2.38	318	-	20.15
0	904	2.67	338	-	24.36
5	1080	3.09	350	-	29.57
10	1288	3.69	349	-	35.94

Test Condition: Subcooling 0 K, Return Gas 20 °C. Data are an indication of performance based simulation.

## PERFORMANCE CURVE

Condensing Temperature 45°C

Evaporating Temperature °C	Cooling Capacity W	Efficiency W/W	Power Consumption W	Current A	Gas Flow Rate kg/h
-20	375	1.37	274	-	11.06
-15	446	1.49	299	-	13.28
-10	531	1.61	329	-	15.95
-5	634	1.76	361	-	19.25
0	758	1.94	391	-	23.36
5	906	2.18	416	-	28.46
10	1084	2.51	431	-	34.72

Test Condition: Subcooling 0 K, Return Gas 20 °C. Data are an indication of performance based simulation.

## PERFORMANCE CURVE

Condensing Temperature 55°C

Evaporating Temperature °C	Cooling Capacity W	Efficiency W/W	Power Consumption W	Current A	Gas Flow Rate kg/h
-10	425	1.22	347	-	15.05
-5	506	1.32	383	-	18.21
0	606	1.44	420	-	22.18
5	726	1.60	454	-	27.14
10	871	1.81	482	-	33.26

Test Condition: Subcooling 0 K, Return Gas 20 °C. Data are an indication of performance based simulation.

## ENVELOPE

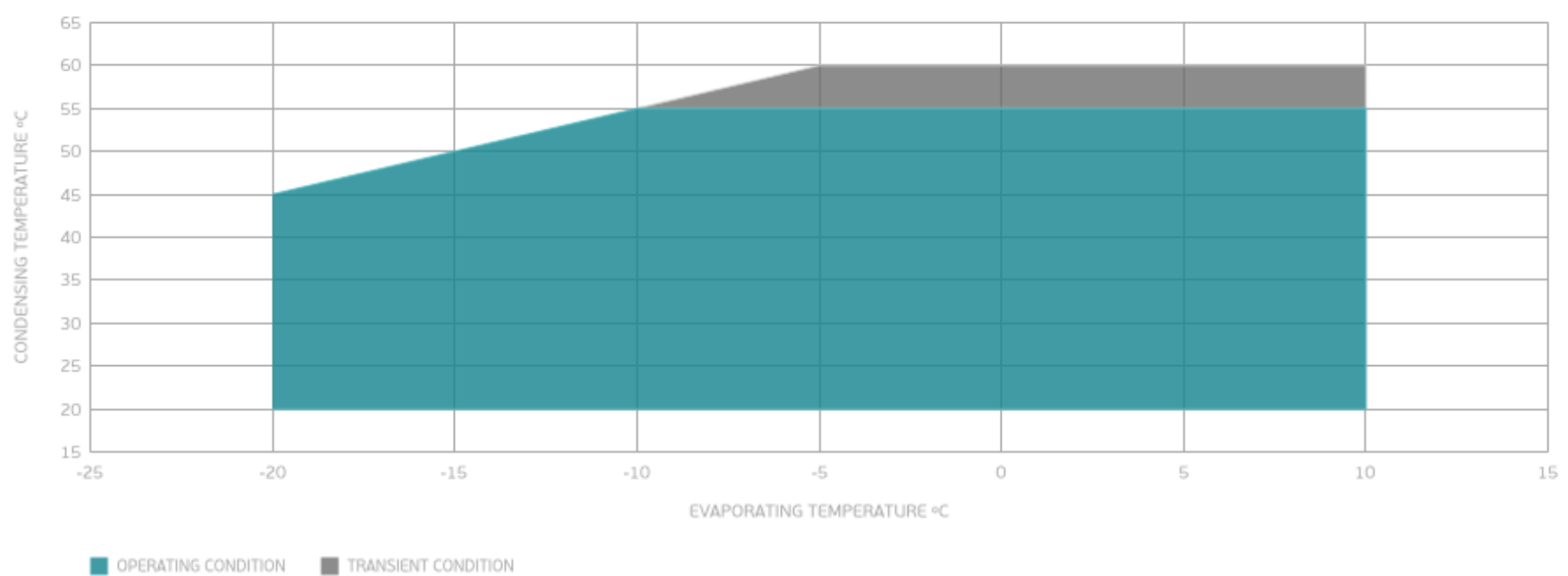

## External

### EXTERNAL CHARACTERISTICS

Base Plate		SMALL	
Tray Holder		NO	
<b>Connector</b>	<b>Internal Diameter</b>	<b>Shape</b>	<b>Material</b>
Suction	8.1 mm	SLANTED 42°	COPPER
Discharge	6.1 mm	STRAIGHT	COPPER

**EXTERNAL DIMENSIONS**

**SHELL**

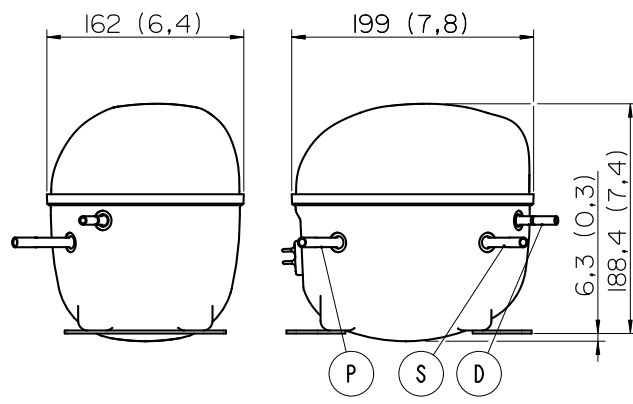

**BASE**



**FENCE**

