

NEK6212Z



ENGINEERING CODE
269AA92



REFRIGERANT
R-134a



POWER SUPPLY
220-240 V 50 Hz



APPLICATION
HBP



MOTOR TYPE
CSIR



STANDARD
EN12900



COOLING CAPACITY
1159 W



EFFICIENCY
1.98 W/W



DATA

GENERAL DATA

Model	NEK6212Z
Type	Hermetic Reciprocating
Technology	ON/OFF
Compressor Application	HBP
Expansion Device	Capillary Tube or Expansion Valve
Compressor Cooling	Fan/220
HP	1/2
Starting Torque	HST
Plant	SLOVAKIA

ELECTRICAL DATA

Start Winding Resistance	27.95 Ω at 25°C
Run Winding Resistance	5.11 Ω at 25°C

MECHANICAL DATA

Displacement	14.28 cm ³
Oil Charge	350 ml
Oil Type	ESTER
Oil Viscosity	ISO22
Weight	11 Kg

ELECTRICAL COMPONENTS

Start Capacitor	72-88 µf/330 V
CSR CSIR BOX	No
Starting Device Type	RELAY
Starting Device Description	MTRP-0012*
Overload Protection	T0741/G6

PERFORMANCE

TESTED CONDITIONS

Tested Refrigerant	R-134a
Tested Application	HBP
Tested Standard	EN12900
Tested Cooling	Fan
Tested Voltage	220 V
Refrigerant Temperature	Dew

RATED POINTS

Condensing Temperature °C	Evaporating Temperature °C	Cooling Capacity W	Efficiency W/W	Power Consumption W	Current A	Gas Flow Rate kg/h
50	5	1159	1.98	585	-	29.09

Test Condition: Subcooling 0 K, Return Gas 20 °C. Data are an indication of performance based simulation.

PERFORMANCE CURVE

Condensing Temperature 35°C

Evaporating Temperature °C	Cooling Capacity W	Efficiency W/W	Power Consumption W	Current A	Gas Flow Rate kg/h
-15	600	1.74	345	-	12.71
-10	751	1.98	379	-	15.97
-5	933	2.23	418	-	19.94
0	1151	2.52	457	-	24.74
5	1408	2.86	492	-	30.51
10	1709	3.30	518	-	37.38

Test Condition: Subcooling 0 K, Return Gas 20 °C. Data are an indication of performance based simulation.

PERFORMANCE CURVE

Condensing Temperature 45°C

Evaporating Temperature °C	Cooling Capacity W	Efficiency W/W	Power Consumption W	Current A	Gas Flow Rate kg/h
-15	528	1.40	378	-	12.24
-10	663	1.61	413	-	15.46
-5	825	1.80	459	-	19.35
0	1018	1.99	511	-	24.04
5	1245	2.21	565	-	29.64
10	1510	2.46	615	-	36.30

Test Condition: Subcooling 0 K, Return Gas 20 °C. Data are an indication of performance based simulation.

PERFORMANCE CURVE

Condensing Temperature 55°C

Evaporating Temperature °C	Cooling Capacity W	Efficiency W/W	Power Consumption W	Current A	Gas Flow Rate kg/h
-10	561	1.32	424	-	14.53
-5	704	1.50	471	-	18.37
0	873	1.65	529	-	22.95
5	1071	1.80	595	-	28.42
10	1301	1.96	664	-	34.90

Test Condition: Subcooling 0 K, Return Gas 20 °C. Data are an indication of performance based simulation.

ENVELOPE



External

EXTERNAL CHARACTERISTICS

Base Plate		UNI	
Tray Holder		NO	
Connector	Internal Diameter	Shape	Material
Suction	8.1 mm	SLANTED 42°	COPPER
Discharge	6.45 mm	STRAIGHT	COPPER
Process	6.45 mm	SLANTED 42°	COPPER

EXTERNAL DIMENSIONS

SHELL

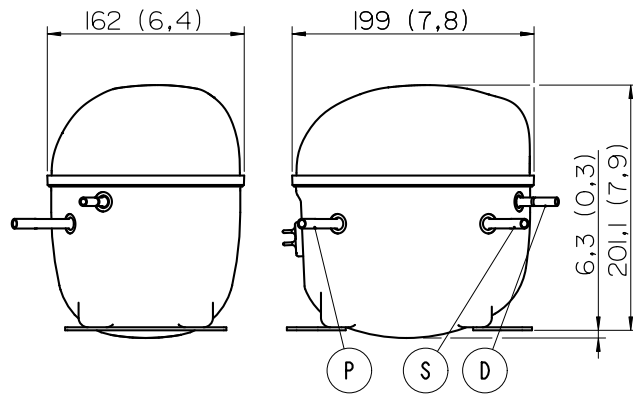

BASE

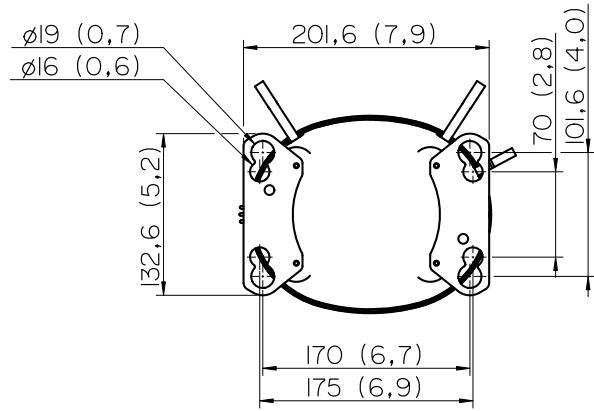

FENCE

