

EMT2130GK



ENGINEERING CODE
913AA62



REFRIGERANT
R-404A



POWER SUPPLY
220-240 V 50 Hz



APPLICATION
LBP



MOTOR TYPE
CSIR



STANDARD
EN12900



COOLING CAPACITY
214 W



EFFICIENCY
1.04 W/W

DATA

GENERAL DATA

Model	EMT2130GK
Type	Hermetic Reciprocating
Technology	ON/OFF
Compressor Application	LBP
Expansion Device	Capillary Tube or Expansion Valve
Compressor Cooling	Fan/220
HP	1/2-
Starting Torque	HST
Plant	ITALY

ELECTRICAL DATA

Start Winding Resistance	17.0 Ω at 25°C
Run Winding Resistance	10.0 Ω at 25°C
Locked Rotor Amperage (LRA) 50Hz	12.4 A

MECHANICAL DATA

Displacement	6.76 cm ³
Oil Charge	180 ml
Oil Type	ESTER
Oil Viscosity	ISO22
Weight	8 Kg

ELECTRICAL COMPONENTS

Start Capacitor	72-88 µf/330 V
CSR CSIR BOX	No
Starting Device Type	RELAY
Starting Device Description	MTRPH-0025-59*
Overload Protection	T0971/G6

PERFORMANCE

TESTED CONDITIONS

Tested Refrigerant	R-404A
Tested Application	LBP
Tested Standard	EN12900
Tested Cooling	Fan
Tested Voltage	220 V
Max Refrigerant Charge	250 g
Refrigerant Temperature	Dew

RATED POINTS

Condensing Temperature °C	Evaporating Temperature °C	Cooling Capacity W	Efficiency W/W	Power Consumption W	Current A	Gas Flow Rate kg/h
40	-35	214	1.04	206	-	5.81

Test Condition: Subcooling 0 K, Return Gas 20 °C. Data are an indication of performance based simulation.

PERFORMANCE CURVE

Condensing Temperature 35°C

Evaporating Temperature °C	Cooling Capacity W	Efficiency W/W	Power Consumption W	Current A	Gas Flow Rate kg/h
-40	182	1.01	179	-	4.61
-35	237	1.17	202	-	6.05
-30	303	1.34	227	-	7.77
-25	381	1.51	253	-	9.82
-20	472	1.69	280	-	12.24
-15	576	1.88	306	-	15.05
-10	694	2.09	333	-	18.31

Test Condition: Subcooling 0 K, Return Gas 20 °C. Data are an indication of performance based simulation.

PERFORMANCE CURVE

Condensing Temperature 45°C

Evaporating Temperature °C	Cooling Capacity W	Efficiency W/W	Power Consumption W	Current A	Gas Flow Rate kg/h
-40	145	0.78	184	-	4.17
-35	192	0.92	209	-	5.55
-30	249	1.05	238	-	7.23
-25	316	1.17	270	-	9.23
-20	394	1.30	304	-	11.60
-15	483	1.42	339	-	14.38
-10	586	1.56	376	-	17.60

Test Condition: Subcooling 0 K, Return Gas 20 °C. Data are an indication of performance based simulation.

PERFORMANCE CURVE

Condensing Temperature 55°C

Evaporating Temperature °C	Cooling Capacity W	Efficiency W/W	Power Consumption W	Current A	Gas Flow Rate kg/h
-30	194	0.80	242	-	6.60
-25	249	0.89	278	-	8.55
-20	313	0.98	318	-	10.86
-15	388	1.07	362	-	13.58
-10	473	1.16	408	-	16.75

Test Condition: Subcooling 0 K, Return Gas 20 °C. Data are an indication of performance based simulation.

ENVELOPE



External

EXTERNAL CHARACTERISTICS

Base Plate SMALL

Tray Holder NO

Connector	Internal Diameter	Shape	Material
Suction	6.1 mm	SLANTED 42°	COPPER
Discharge	4.94 mm	STRAIGHT	COPPER
Process	6.1 mm	SLANTED 42°	COPPER

EXTERNAL DIMENSIONS

SHELL

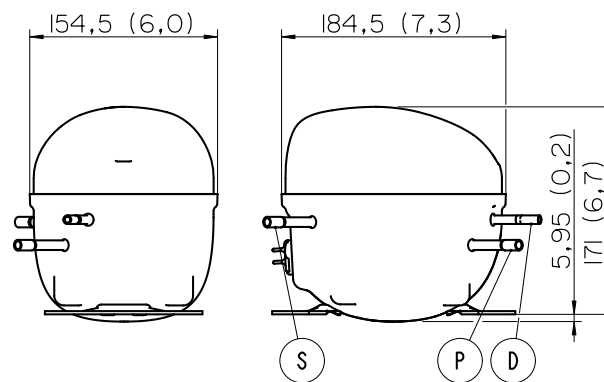

BASE



FENCE

