

EMT6144U



**ENGINEERING CODE**  
513306232

**REFRIGERANT**  
R-290

**POWER SUPPLY**  
220-240 V 50 Hz

**APPLICATION**  
MBP

**MOTOR TYPE**  
CSIR

**STANDARD**  
EN12900

**COOLING CAPACITY**  
336 W

**EFFICIENCY**  
1.95 W/W



DATA

GENERAL DATA

Model	EMT6144U
Type	Hermetic Reciprocating
Technology	ON/OFF
Compressor Application	MBP
Expansion Device	Capillary Tube or Expansion Valve
Compressor Cooling	Static/220
HP	1/4-
Starting Torque	HST
Plant	BRAZIL

ELECTRICAL DATA

Start Winding Resistance	21.1 Ω at 25°C
Run Winding Resistance	14.4 Ω at 25°C

## MECHANICAL DATA

Displacement	4.5 cm <sup>3</sup>
Oil Charge	180 ml
Oil Type	ESTER
Oil Viscosity	ISO22
Weight	7.8 Kg

## ELECTRICAL COMPONENTS

Start Capacitor	43-53 µf/330 V
CSR CSIR BOX	No
Starting Device Type	RELAY
Starting Device Description	MTRP-0015* QL2-3.76 ***
Overload Protection	DRB180K52AXF

## PERFORMANCE

### TESTED CONDITIONS

Tested Refrigerant	R-290
Tested Application	MBP
Tested Standard	EN12900
Tested Cooling	Static
Tested Voltage	220 V
Max Refrigerant Charge	150 g
Refrigerant Temperature	Dew

### RATED POINTS

Condensing Temperature °C	Evaporating Temperature °C	Cooling Capacity W	Efficiency W/W	Power Consumption W	Current A	Gas Flow Rate kg/h
45	-10	336	1.95	172	-	4.13

Test Condition: Subcooling 0 K, Return Gas 20 °C. Data are an indication of performance based simulation.

**PERFORMANCE CURVE**

**Condensing Temperature 35°C**

Evaporating Temperature °C	Cooling Capacity W	Efficiency W/W	Power Consumption W	Current A	Gas Flow Rate kg/h
-20	258	1.89	137	-	2.86
-15	318	2.19	145	-	3.54
-10	388	2.53	153	-	4.35
-5	471	2.93	161	-	5.31
0	566	3.40	166	-	6.42
5	673	4.00	168	-	7.71
10	794	4.80	166	-	9.19

Test Condition: Subcooling 0 K, Return Gas 20 °C. Data are an indication of performance based simulation.

**PERFORMANCE CURVE**

**Condensing Temperature 45°C**

Evaporating Temperature °C	Cooling Capacity W	Efficiency W/W	Power Consumption W	Current A	Gas Flow Rate kg/h
-20	223	1.47	151	-	2.71
-15	274	1.71	161	-	3.36
-10	336	1.95	172	-	4.13
-5	407	2.22	184	-	5.05
0	491	2.52	195	-	6.13
5	585	2.87	204	-	7.39
10	693	3.30	210	-	8.84

Test Condition: Subcooling 0 K, Return Gas 20 °C. Data are an indication of performance based simulation.

**PERFORMANCE CURVE**

**Condensing Temperature 55°C**

Evaporating Temperature °C	Cooling Capacity W	Efficiency W/W	Power Consumption W	Current A	Gas Flow Rate kg/h
-10	283	1.55	183	-	3.89
-5	344	1.74	198	-	4.77
0	415	1.95	213	-	5.80
5	497	2.18	228	-	7.02
10	590	2.44	241	-	8.42

Test Condition: Subcooling 0 K, Return Gas 20 °C. Data are an indication of performance based simulation.

## ENVELOPE

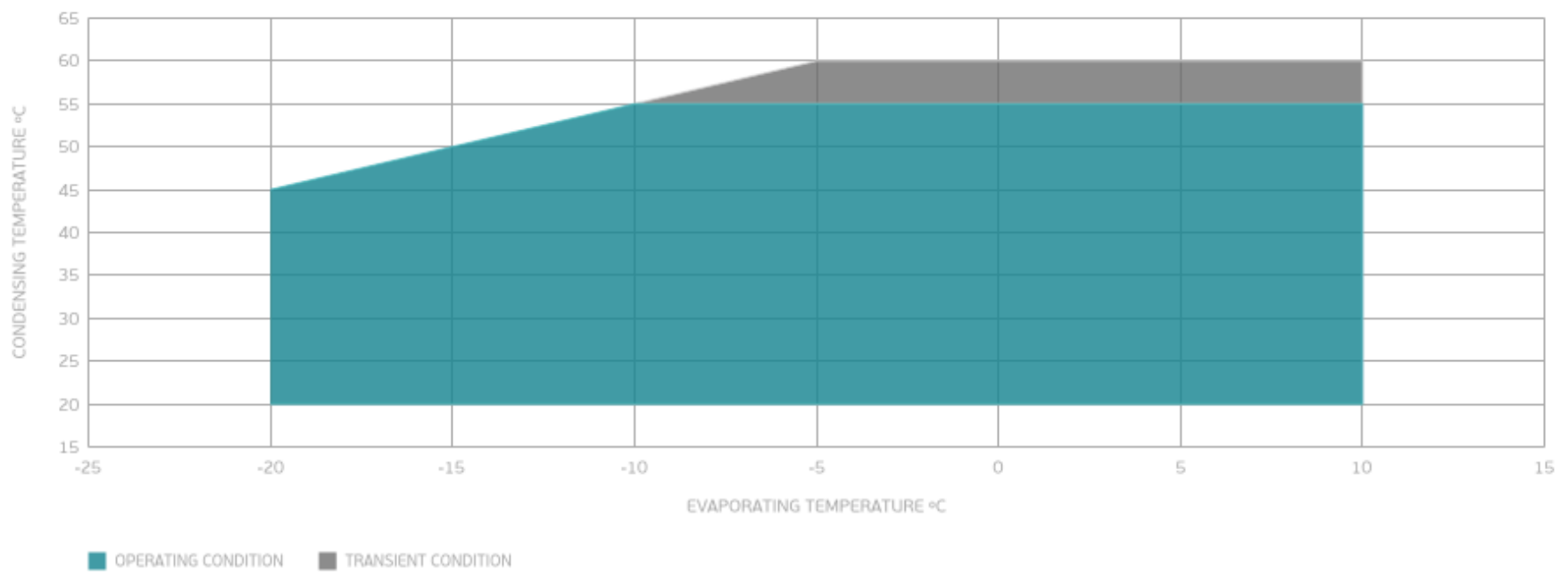

## External

### EXTERNAL CHARACTERISTICS

Base Plate SMALL EUEM

Tray Holder YES

Connector	Internal Diameter	Shape	Material
Suction	6.1 mm	SLANTED 42° UP + 45° TO BACK	COPPER
Discharge	4.94 mm	SLANTED PARALLEL BP+24° TO BACK	COPPER
Process	6.1 mm	SLANTED 45° UP + 45° TO BACK	COPPER

### EXTERNAL DIMENSIONS

#### SHELL

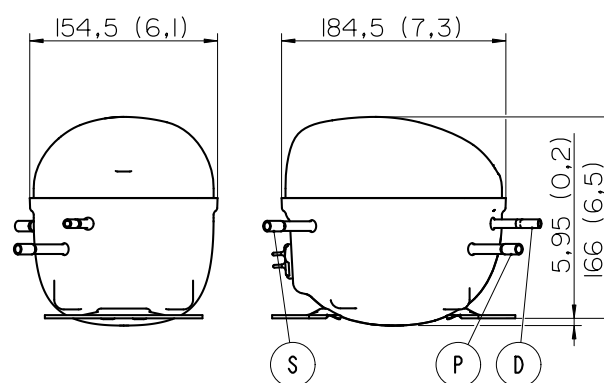

#### BASE



#### FENCE

