

NEU6210U



ENGINEERING CODE
862PA51



REFRIGERANT
R-290



POWER SUPPLY
220-240 V 50 Hz



APPLICATION
MBP



MOTOR TYPE
CSIR



STANDARD
EN12900



COOLING CAPACITY
647 W



EFFICIENCY
1.79 W/W



DATA

GENERAL DATA

Model	NEU6210U
Type	Hermetic Reciprocating
Technology	ON/OFF
Compressor Application	MBP
Expansion Device	Capillary Tube or Expansion Valve
Compressor Cooling	Fan/220
HP	1/3
Starting Torque	HST
Plant	SLOVAKIA

ELECTRICAL DATA

Start Winding Resistance	14.1 Ω at 25°C
Run Winding Resistance	5.97 Ω at 25°C
Locked Rotor Amperage (LRA) 50Hz	18 A

MECHANICAL DATA

Displacement	8.77 cm ³
Oil Charge	350 ml
Oil Type	AB
Oil Viscosity	ISO32
Weight	10.3 Kg

ELECTRICAL COMPONENTS

Start Capacitor	53-64 µf/330 V
CSR CSIR BOX	No
Starting Device Type	RELAY
Starting Device Description	MTRP-0030*
Overload Protection	MST26ALK-3259

PERFORMANCE

TESTED CONDITIONS

Tested Refrigerant	R-290
Tested Application	MBP
Tested Standard	EN12900
Tested Cooling	Fan
Tested Voltage	220 V
Refrigerant Temperature	Dew

RATED POINTS

Condensing Temperature °C	Evaporating Temperature °C	Cooling Capacity W	Efficiency W/W	Power Consumption W	Current A	Gas Flow Rate kg/h
45	-10	647	1.79	361	3.14	7.96

Test Condition: Subcooling 0 K, Return Gas 20 °C. Data generated in accordance to EN 12900:2013 polynomial equation and tolerance guidelines.

PERFORMANCE CURVE

Condensing Temperature 35°C

Evaporating Temperature °C	Cooling Capacity W	Efficiency W/W	Power Consumption W	Current A	Gas Flow Rate kg/h
-20	494	1.67	296	3.03	5.48
-15	616	1.97	313	3.06	6.86
-10	757	2.29	331	3.09	8.48
-5	920	2.65	346	3.11	10.36
0	1105	3.10	357	3.13	12.54
5	1313	3.67	358	3.15	15.04
10	1547	4.47	346	3.16	17.90

Test Condition: Subcooling 0 K, Return Gas 20 °C. Data generated in accordance to EN 12900:2013 polynomial equation and tolerance guidelines.

PERFORMANCE CURVE

Condensing Temperature 45°C

Evaporating Temperature °C	Cooling Capacity W	Efficiency W/W	Power Consumption W	Current A	Gas Flow Rate kg/h
-20	416	1.29	322	3.06	5.07
-15	522	1.54	339	3.10	6.39
-10	647	1.79	361	3.14	7.96
-5	791	2.06	384	3.18	9.79
0	955	2.36	405	3.22	11.94
5	1143	2.72	420	3.26	14.42
10	1353	3.18	426	3.30	17.27

Test Condition: Subcooling 0 K, Return Gas 20 °C. Data generated in accordance to EN 12900:2013 polynomial equation and tolerance guidelines.

PERFORMANCE CURVE

Condensing Temperature 55°C

Evaporating Temperature °C	Cooling Capacity W	Efficiency W/W	Power Consumption W	Current A	Gas Flow Rate kg/h
-10	542	1.45	374	3.17	7.44
-5	665	1.66	401	3.22	9.21
0	808	1.88	430	3.27	11.30
5	972	2.13	456	3.32	13.73
10	1158	2.43	476	3.37	16.54

Test Condition: Subcooling 0 K, Return Gas 20 °C. Data generated in accordance to EN 12900:2013 polynomial equation and tolerance guidelines.

ENVELOPE

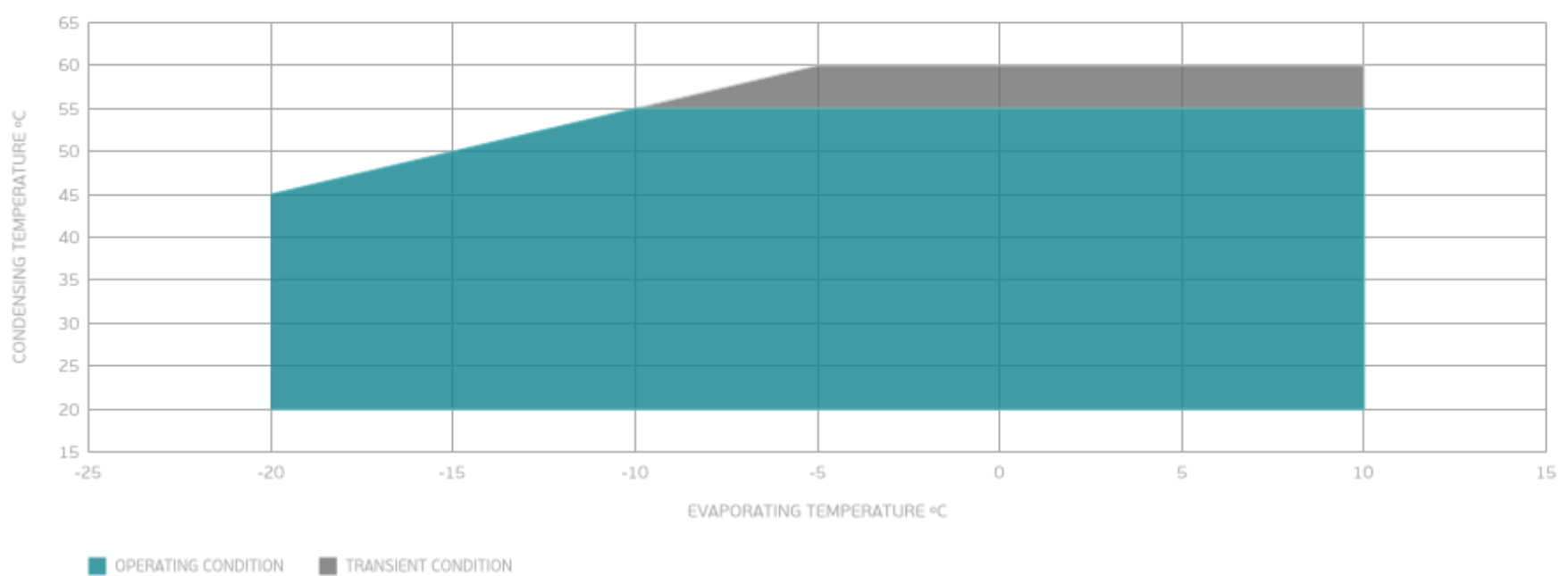

External

EXTERNAL CHARACTERISTICS

Base Plate		SMALL	
Tray Holder		NO	
Connector	Internal Diameter	Shape	Material
Suction	8.1 mm	SLANTED 42°	COPPER
Discharge	6.1 mm	STRAIGHT	COPPER

EXTERNAL DIMENSIONS

SHELL

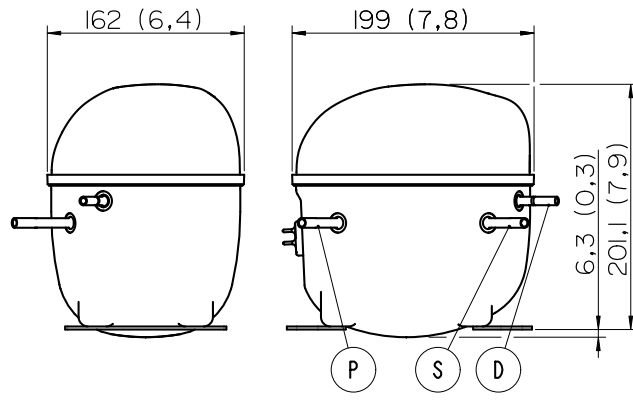

BASE



FENCE

