

NEU6212U



**ENGINEERING CODE**  
862HA51



**REFRIGERANT**  
R-290



**POWER SUPPLY**  
220-240 V 50 Hz



**APPLICATION**  
MBP



**MOTOR TYPE**  
CSIR



**STANDARD**  
EN12900



**COOLING CAPACITY**  
773 W



**EFFICIENCY**  
1.91 W/W



DATA

GENERAL DATA

Model	NEU6212U
Type	Hermetic Reciprocating
Technology	ON/OFF
Compressor Application	MBP
Expansion Device	Capillary Tube or Expansion Valve
Compressor Cooling	Fan/220
HP	1/2
Starting Torque	HST
Plant	SLOVAKIA

ELECTRICAL DATA

Start Winding Resistance	27.92 Ω at 25°C
Run Winding Resistance	4.53 Ω at 25°C
Locked Rotor Amperage (LRA) 50Hz	20.5 A
Rated Load Amperage (LMBP) at 50 Hz	2.8 A

## MECHANICAL DATA

Displacement	9.99 cm <sup>3</sup>
Oil Charge	350 ml
Oil Type	AB
Oil Viscosity	ISO32
Weight	11.2 Kg

## ELECTRICAL COMPONENTS

Start Capacitor	53-64 µf/330 V
CSR CSIR BOX	No
Starting Device Type	RELAY
Starting Device Description	MTRP-0012*
Overload Protection	4TM758PFB

## PERFORMANCE

### TESTED CONDITIONS

Tested Refrigerant	R-290
Tested Application	MBP
Tested Standard	EN12900
Tested Cooling	Fan
Tested Voltage	220 V
Refrigerant Temperature	Dew

### RATED POINTS

Condensing Temperature °C	Evaporating Temperature °C	Cooling Capacity W	Efficiency W/W	Power Consumption W	Current A	Gas Flow Rate kg/h
45	-10	773	1.91	405	-	9.51

Test Condition: Subcooling 0 K, Return Gas 20 °C. Data are an indication of performance based simulation.

### PERFORMANCE CURVE

Condensing Temperature 35°C

Evaporating Temperature °C	Cooling Capacity W	Efficiency W/W	Power Consumption W	Current A	Gas Flow Rate kg/h
-20	595	1.82	326	-	6.59
-15	732	2.11	347	-	8.16
-10	891	2.42	368	-	9.98
-5	1075	2.78	386	-	12.10
0	1286	3.23	398	-	14.59
5	1528	3.81	401	-	17.49
10	1802	4.62	390	-	20.86

Test Condition: Subcooling 0 K, Return Gas 20 °C. Data are an indication of performance based simulation.

## PERFORMANCE CURVE

Condensing Temperature 45°C

Evaporating Temperature °C	Cooling Capacity W	Efficiency W/W	Power Consumption W	Current A	Gas Flow Rate kg/h
-20	507	1.42	356	-	6.17
-15	630	1.66	379	-	7.71
-10	773	1.91	405	-	9.51
-5	938	2.17	433	-	11.62
0	1127	2.46	458	-	14.09
5	1345	2.82	477	-	16.97
10	1593	3.28	486	-	20.32

Test Condition: Subcooling 0 K, Return Gas 20 °C. Data are an indication of performance based simulation.

## PERFORMANCE CURVE

Condensing Temperature 55°C

Evaporating Temperature °C	Cooling Capacity W	Efficiency W/W	Power Consumption W	Current A	Gas Flow Rate kg/h
-10	655	1.54	427	-	9.00
-5	800	1.74	460	-	11.07
0	967	1.96	494	-	13.51
5	1159	2.21	525	-	16.37
10	1379	2.50	551	-	19.70

Test Condition: Subcooling 0 K, Return Gas 20 °C. Data are an indication of performance based simulation.

## ENVELOPE

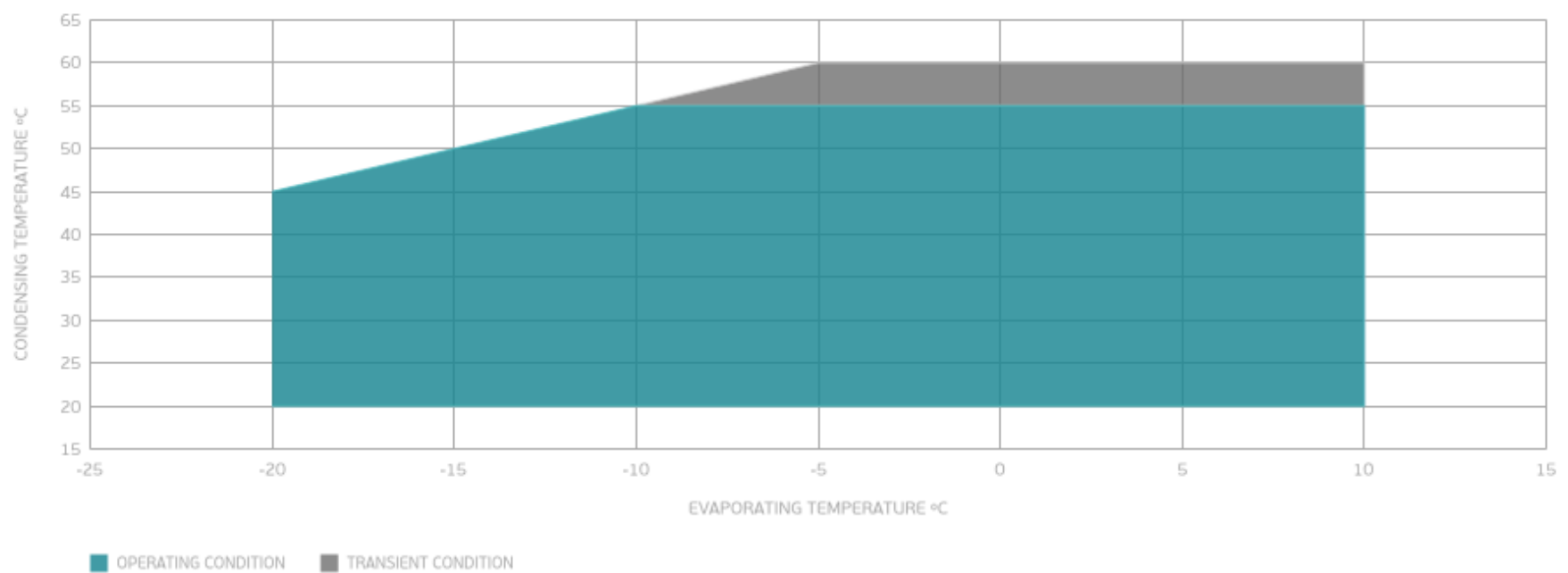

## External

### EXTERNAL CHARACTERISTICS

Base Plate		SMALL	
Tray Holder		NO	
<b>Connector</b>	<b>Internal Diameter</b>	<b>Shape</b>	<b>Material</b>
Suction	8.1 mm	SLANTED 42°	COPPER
Discharge	6.1 mm	STRAIGHT	COPPER

EXTERNAL DIMENSIONS

SHELL

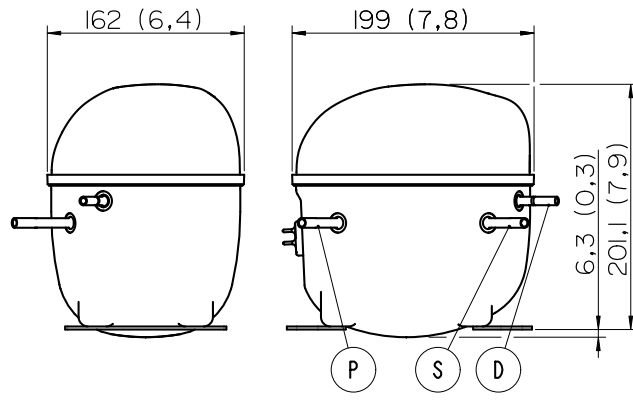

BASE



FENCE

