

NJX2215U

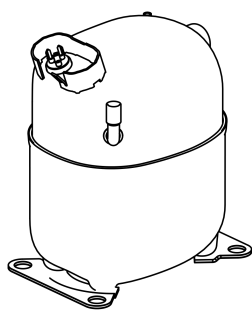

ENGINEERING CODE
887FA21

REFRIGERANT
R-290

POWER SUPPLY
220-240 V 50 Hz

APPLICATION
LBP

MOTOR TYPE
CSCR

STANDARD
EN12900

COOLING CAPACITY
943 W

EFFICIENCY
1.25 W/W



DATA

GENERAL DATA

Model	NJX2215U
Type	Hermetic Reciprocating
Technology	ON/OFF
Compressor Application	LBP
Expansion Device	Capillary Tube or Expansion Valve
Compressor Cooling	Fan/220
HP	1 3/4
Starting Torque	HST
Plant	SLOVAKIA

ELECTRICAL DATA

Start Winding Resistance	4.3 Ω at 25°C
Run Winding Resistance	1.78 Ω at 25°C
Locked Rotor Amperage (LRA) 50Hz	34 A

MECHANICAL DATA

Displacement	37.88 cm ³
Oil Charge	750 ml
Oil Type	ESTER
Oil Viscosity	ISO22
Weight	22 Kg

ELECTRICAL COMPONENTS

Start Capacitor	108-130 µf/330 V
Run Capacitor	20.0 µf/400 V
CSR CSIR BOX	Yes
Starting Device Description	RVA3H3C-108
Overload Protection	15HM1994-248 (internal)

PERFORMANCE

TESTED CONDITIONS

Tested Refrigerant	R-290
Tested Application	LBP
Tested Standard	EN12900
Tested Cooling	Fan
Tested Voltage	220 V
Max Refrigerant Charge	500 g
Refrigerant Temperature	Dew

RATED POINTS

Condensing Temperature °C	Evaporating Temperature °C	Cooling Capacity W	Efficiency W/W	Power Consumption W	Current A	Gas Flow Rate kg/h
40	-35	943	1.25	755	4.01	10.83

Test Condition: Subcooling 0 K, Return Gas 20 °C. Data generated in accordance to EN 12900:2013 polynomial equation and tolerance guidelines.

PERFORMANCE CURVE

Condensing Temperature 35°C

Evaporating Temperature °C	Cooling Capacity W	Efficiency W/W	Power Consumption W	Current A	Gas Flow Rate kg/h
-40	771	1.21	637	3.50	8.44
-35	1022	1.39	735	3.93	11.22
-30	1332	1.59	840	4.38	14.66
-25	1702	1.80	946	4.83	18.79
-20	2130	2.03	1050	5.30	23.61
-15	2616	2.28	1147	5.77	29.14
-10	3161	2.57	1231	6.26	35.39

Test Condition: Subcooling 0 K, Return Gas 20 °C. Data generated in accordance to EN 12900:2013 polynomial equation and tolerance guidelines.

PERFORMANCE CURVE

Condensing Temperature 45°C

Evaporating Temperature °C	Cooling Capacity W	Efficiency W/W	Power Consumption W	Current A	Gas Flow Rate kg/h
-40	642	0.97	663	3.58	7.70
-35	861	1.12	770	4.06	10.37
-30	1132	1.27	890	4.57	13.67
-25	1455	1.43	1018	5.10	17.63
-20	1829	1.59	1149	5.65	22.26
-15	2253	1.76	1278	6.23	27.57
-10	2728	1.95	1400	6.83	33.57

Test Condition: Subcooling 0 K, Return Gas 20 °C. Data generated in accordance to EN 12900:2013 polynomial equation and tolerance guidelines.

PERFORMANCE CURVE

Condensing Temperature 55°C

Evaporating Temperature °C	Cooling Capacity W	Efficiency W/W	Power Consumption W	Current A	Gas Flow Rate kg/h
-30	919	1.01	913	4.73	12.36
-25	1196	1.13	1058	5.35	16.15
-20	1517	1.25	1212	6.02	20.58
-15	1880	1.37	1369	6.72	25.66
-10	2287	1.50	1526	7.45	31.41

Test Condition: Subcooling 0 K, Return Gas 20 °C. Data generated in accordance to EN 12900:2013 polynomial equation and tolerance guidelines.

ENVELOPE



External

EXTERNAL CHARACTERISTICS

Base Plate LARGE

Tray Holder NO

Connector	Internal Diameter	Shape	Material
Suction	12.81 mm	VERTICAL	COPPER
Discharge	8.04 mm	SLANTED J	COPPER
Process	6.45 mm	VERTICAL	COPPER

EXTERNAL DIMENSIONS

SHELL

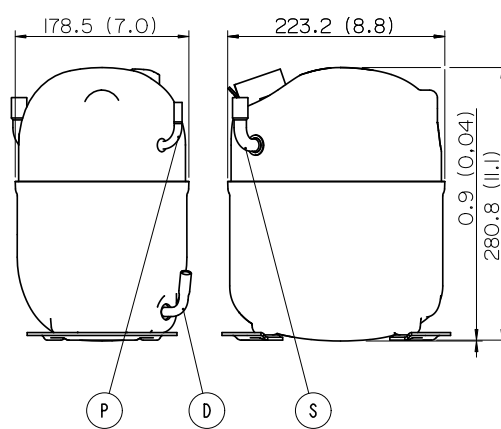

BASE

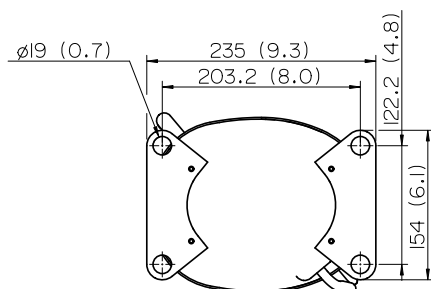

FENCE

